



SOCAA

Solution of Connector & Antenna Co., LTD

2017



CONTENTS

目錄

成品接頭編碼原則 Connector	
Model No. Coding Pattern -----	01
SMA-Series -----	02
RPSMA-Series -----	14
N-Series -----	24
MCX-Series -----	34
MMCX-Series -----	44
TNC-Series -----	52
RPTNC-Series -----	58
BNC-Series -----	64
SMB-Series -----	72

T轉接頭編碼原則 Adaptor	
Model No. Coding Pattern -----	81
Adaptor-Series -----	82
避雷器編碼原則 Lightning Arrestor	
Model No. Coding Pattern -----	97
Lightning Arrestor-Series -----	98
天線編碼原則 Antenna	
Model No. Coding Pattern -----	105
Antenna Series -----	106
組裝流程 Assembly Flowchart -----	114

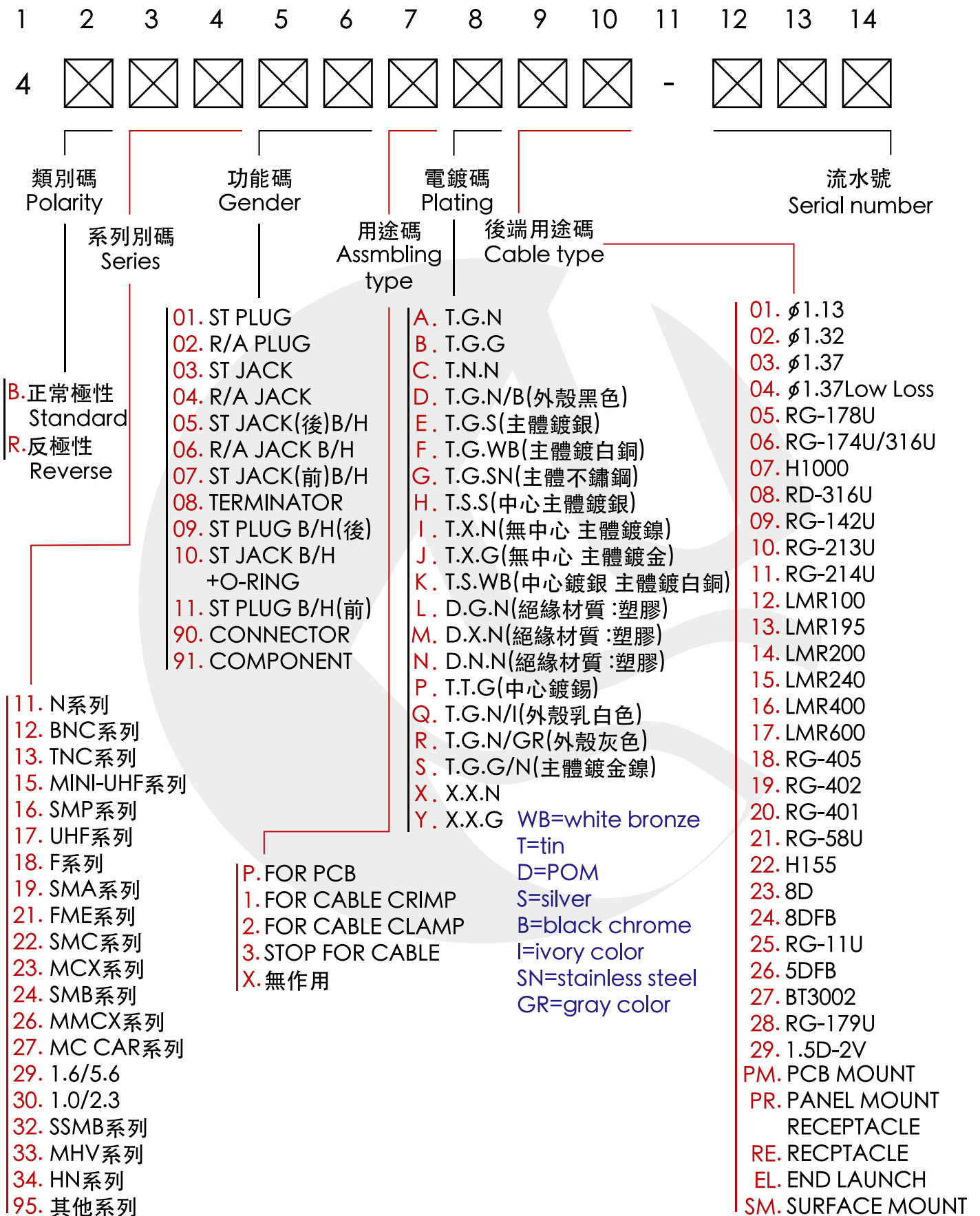

SMA-Series

N-Series

MCX-Series

MMCX-Series

TNC-Series

BNC-Series

SMB-Series

ADAPTE

Light

A

Product Specs Chart

LightningArrestor-Series ANTENNA-Series



MODEL NUMBER PATTERN
□□□□□□□□□□ - □□□□
XXXXXXXXXX-XXX

Electrical

Impedance 50ohm

Frequency Range 0 to 18 GHz
for RG-402 & RG-405 semi-rigid cable-0 to 18.0 GHz
for flexible cable : 0-12.4 GHz

VSWR 1.05+0.015xf GHz max (Straight)
1.15+0.015xf GHz max (Right Angle)
RG-402(.141"OD) → 1.05+0.01xf GHz max(Straight)
1.10+0.01xf GHz max (Right Angle)
RG-405(.085"OD) → 1.05+0.01xf GHz max(Straight)
1.10+0.01xf GHz max (Right Angle)
RG-58,141,142,223 → 1.10+0.01xf GHz max(Straight)
1.15+0.02xf GHz max (Right Angle)
RG-174,188,316 → 1.15+0.01xf GHz max(Straight)
1.18+0.02xf GHz max (Right Angle)
RG-178,196 → 1.20+0.02xf GHz max(Straight)
1.18+0.02xf GHz max (Right Angle)

Voltage Rating RG-402(.141"OD) → 500 volts rms max
RG-405(.085"OD) → 355 volts rms max
RG-58,141,142,223 → 500 volts rms max
RG-174,188,316 → 355 volts rms max
RG-178,196 → 250 volts rms max

Dielectric Withstanding Voltage RG-402(.141"OD) → 1000 volts rms max
RG-405(.085"OD) → 750 volts rms max
RG-58,141,142,223 → 1000 volts rms max
RG-174,188,316 → 750 volts rms max
RG-178,196 → 500 volts rms max

Contact Resistance Center contact=2.0 Milliohms max
Outer contact=2.0 Milliohms max

RF Leskage -60dB minimum at 3 GHz

Insertion Loss 0.06dB max x√f at 6 GHz

Insulation Resistance 5000 Megaohms min

Mechanical & Environmental

Mating	1/4"-36threaded coupling
Durability	500 matings
Coupling Nut Retention	60 lbs min
Recommend Nut Mating Torque	8 inch-pounds
Cable Retention	RG-174,188,316 → 20 lbs min RG-58,141,142,223 → 40 lbs min
Temperature Range	-65 °C to 165 °C
Vibration	MIL-STD-202 Method 204 Test Cond.B.
Salt Spray	MIL-STD-202 Method 201 Test Cond.B.
Temperature Cycling	MIL-STD-202 Method 107 Test Cond.B.

Material

	Material	Plating
Connector Body	Brass	Gold or Nickel
Center Contact	Male:Brass Female:Beryllium Copper	Gold Gold
Insulation	Teflon	None
Gasket	Silicone Rubber,Rubber	None
Crimp Ferrule	Annealed Copper	Same as Body

Interface Mating Dimensions

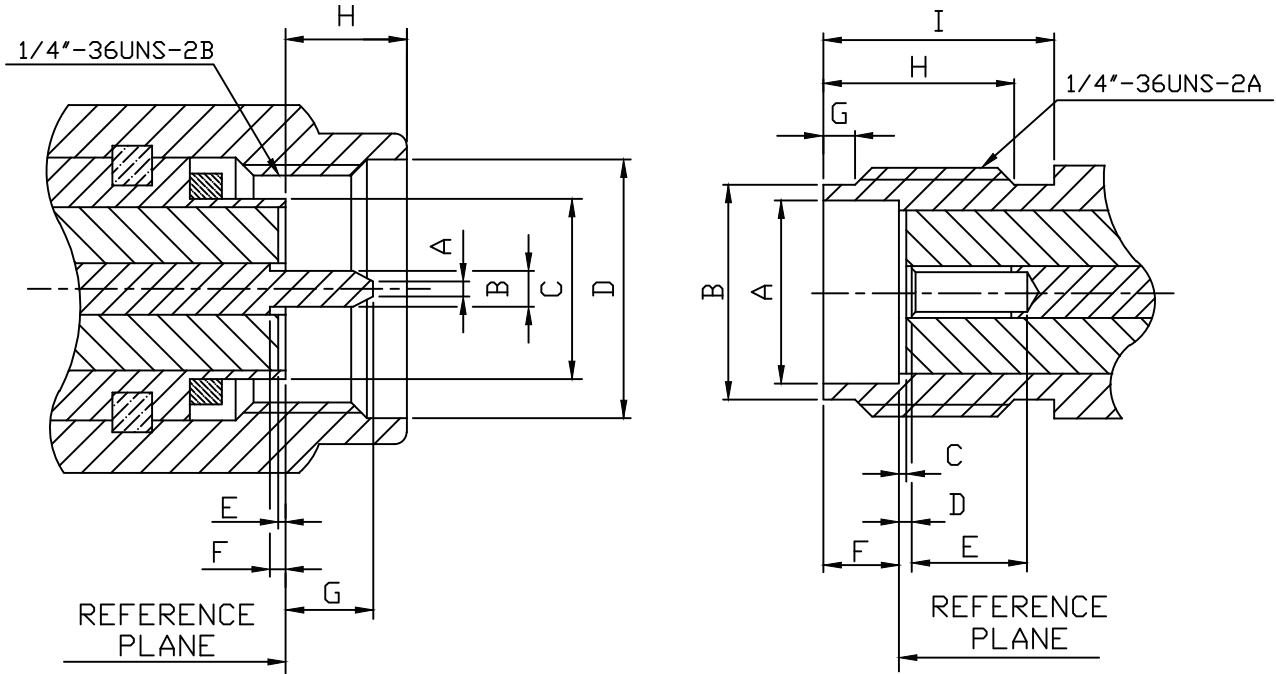

PLUG

Letter	Millimeters (Inches)	
	Minimum	Maximum
A	0.00 (.000)	0.30 (.012)
B	0.90 (.0355)	0.94 (.037)
C	-	4.59 (.1808)
D	6.35 (.250)	-
E	0.00 (.000)	0.25 (.010)
F	0.00 (.000)	0.25 (.010)
G	-	2.54 (.100)
H	-	3.43 (.135)

JACK

Letter	Millimeters (Inches)	
	Minimum	Maximum
A	4.60 (.1810)	-
B	5.28 (.208)	5.49 (.216)
C	0.00 (.000)	0.25 (.010)
D	0.00 (.000)	0.25 (.010)
E	2.67 (.105)	-
F	1.88 (.074)	1.98 (.078)
G	0.38 (.015)	1.14 (.045)
H	4.32 (.170)	-
I	5.54 (.218)	-



SMA Straight Plug Crimp

MODEL 4B19011B01
CABLE ϕ 1.13/ ϕ 1.32
 ϕ 1.37/RG178U

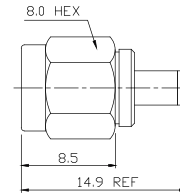
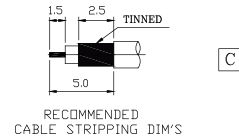

SMA Straight Plug Crimp

MODEL 4B19011B06
CABLE RG174U/RG316

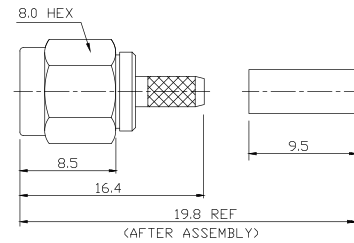
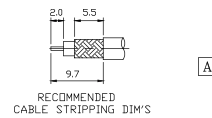

SMA Straight Plug Crimp

MODEL 4B19011B21
CABLE RG58U/RG142U

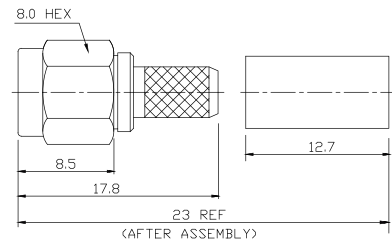
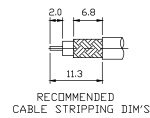

SMA Straight Plug Crimp

MODEL 4B19011B16
CABLE LMR400

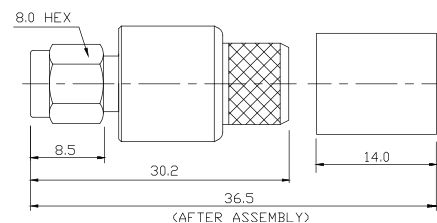
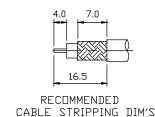



SMA Right Angle Plug Crimp

MODEL 4B19021B01
CABLE ϕ 1.13/ ϕ 1.32
 ϕ 1.37/RG178U

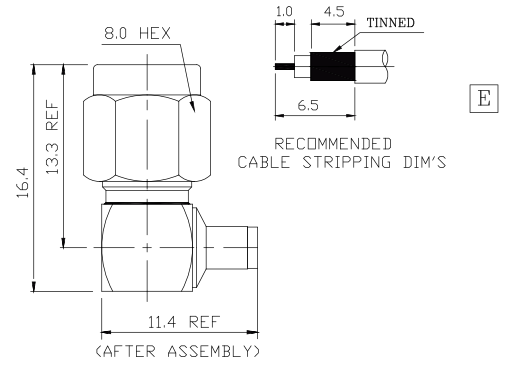

SMA Right Angle Plug Crimp

MODEL 4B19021B06
CABLE RG174U/RG316

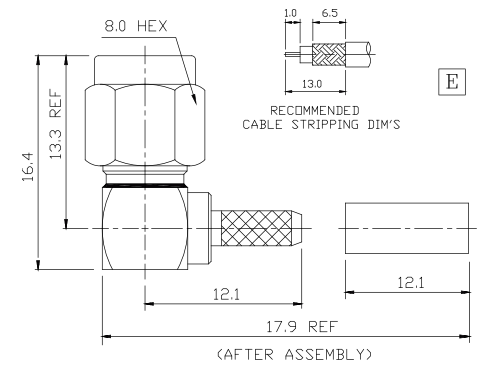

SMA Right Angle Plug Crimp

MODEL 4B19021B21
CABLE RG58U/RG142U

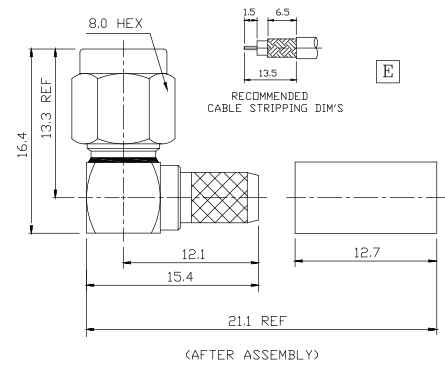

SMA Right Angle Plug Crimp

MODEL 4B19021B18
CABLE RG405

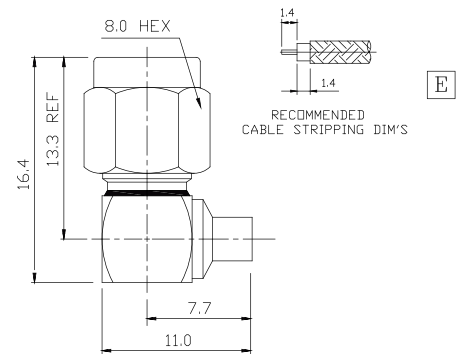



SMA Right Angle Jack PCB Mount

MODEL 4B1904PBPM
CABLE PCB Mount

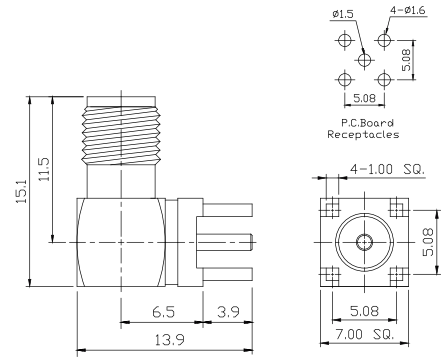

SMA Right Angle Jack PCB Mount Crimp

MODEL 4B1904PB01
CABLE ϕ 1.13/ ϕ 1.32
 ϕ 1.37/RG178U

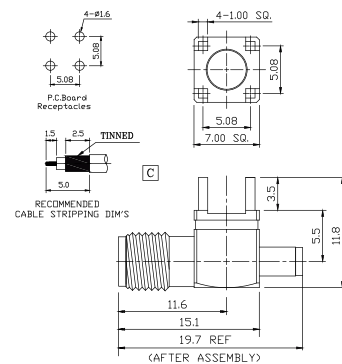

SMA Right Angle Jack PCB Mount Crimp

MODEL 4B1904PB06
CABLE RG174U/RG316

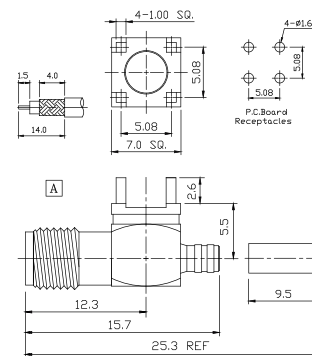

SMA Straight Jack Crimp

MODEL 4B19031B16
CABLE LMR400

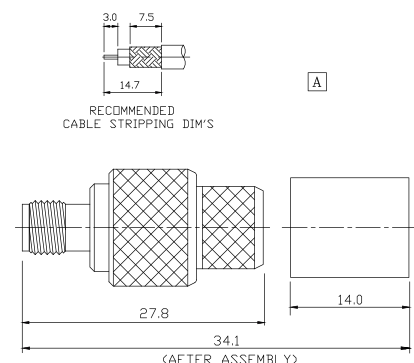



SMA Straight Bulkhead Jack Crimp

MODEL 4B19071B01
CABLE ϕ 1.13/ ϕ 1.32
 ϕ 1.37/RG178U

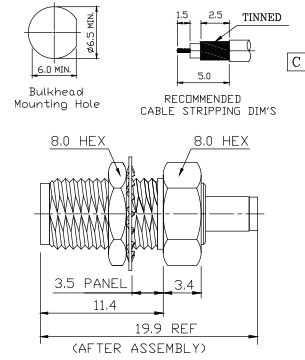

SMA Straight Bulkhead Jack Crimp

MODEL 4B19071B06
CABLE RG174U/RG316

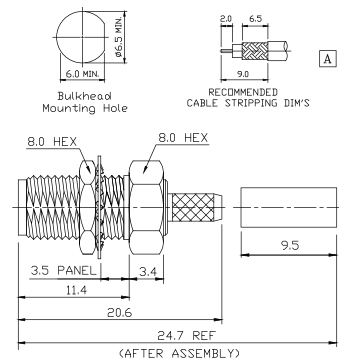

SMA Straight Bulkhead Jack Crimp

MODEL 4B19071B21
CABLE RG58U/RG142U

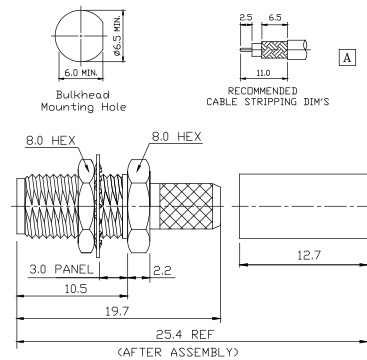

SMA Straight Bulkhead Jack Crimp

MODEL 4B19101B06
CABLE RG174U/RG316

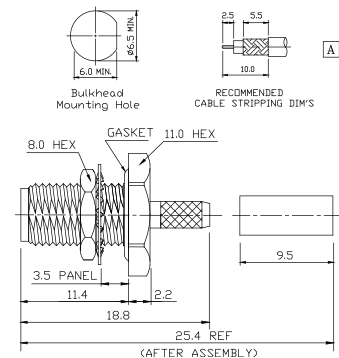



SMA Straight Bulkhead Jack Crimp

MODEL 4B19101B21
CABLE RG174U/RG142U

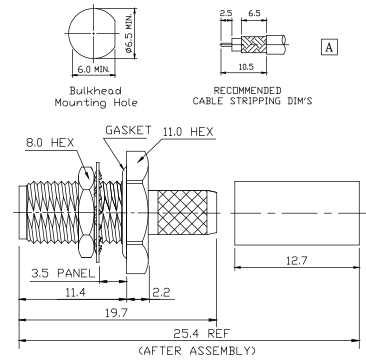

SMA Straight Bulkhead Jack Crimp

MODEL 4B19101B01
CABLE $\phi 1.13/\phi 1.32$
 $\phi 1.37$ /RG178U

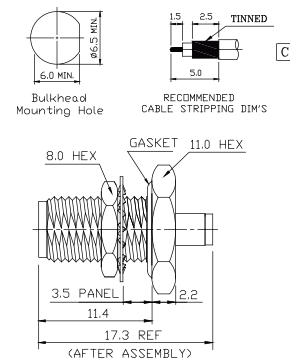

SMA Panel Mount Plug Receptacle 4 Hole SQ Flange

MODEL 4B1901PBPR
CABLE Panel Mount

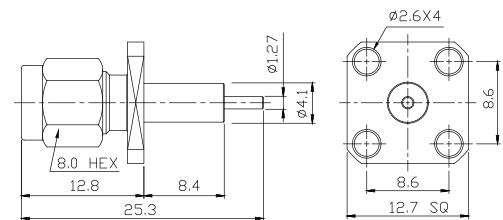

SMA Panel Mount Jack Receptacle

MODEL 4B1903PBPR
CABLE Panel Mount

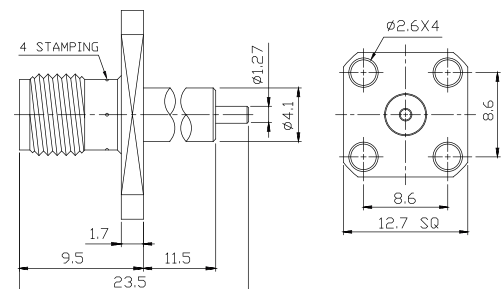



SMA Flange Jack Receptacle

MODEL 4B1903PBPE
CABLE Flange Receptacle

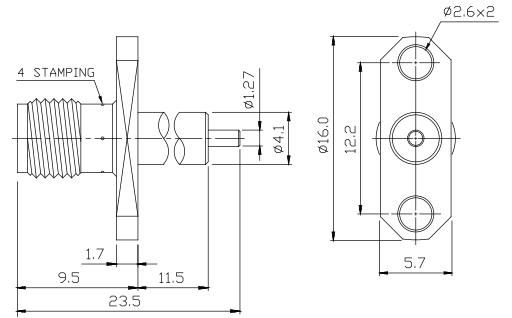

SMA Straight Jack PCB Mount Receptacle

MODEL 4B1903PBPM
CABLE PCB Mount

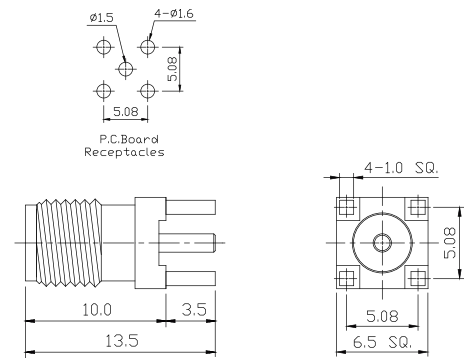

SMA Straight Plug Crimp

MODEL 4B19011B18
CABLE RG405/RG402

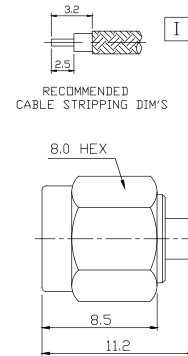

SMA Straight Jack Crimp

MODEL 4B19031B01
CABLE $\phi 1.13/\phi 1.32$
 $\phi 1.37$ /RG178U

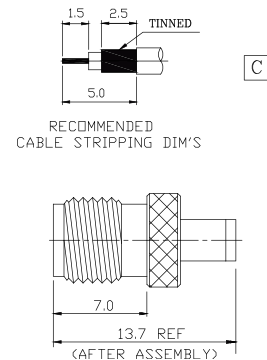

SMA Straight Jack Crimp



MODEL 4B19031B06
CABLE RG174U/RG316U

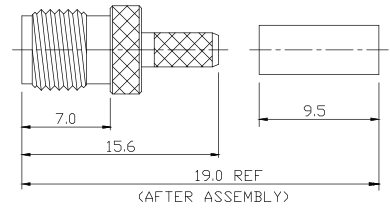
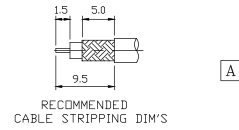

SMA Straight Jack Crimp



MODEL 4B19031B21
CABLE RG58U/RG142U

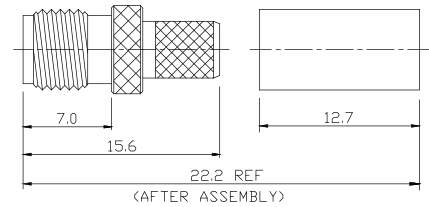
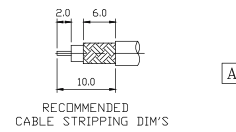

SMA Straight Jack Receptacle



MODEL 4B1903PBEL
CABLE End Launch

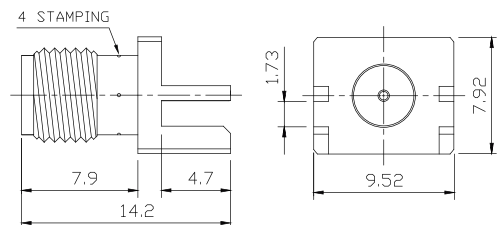

SMA Straight Jack Surface Mount



MODEL 4B1903PBSM
CABLE Surface Mount

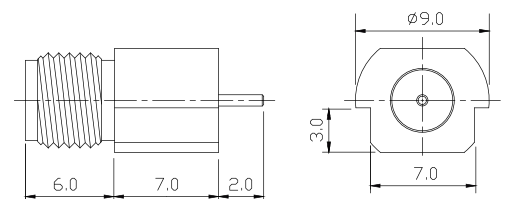

RP SMA-Series

N-Series

MCX-Series

MMCX-Series

TNC-Series

BNC-Series

SMB-Series

ADAPT

Light

A

Product Specs Chart

LightningArrestor-Series
ANTENNA-Series



MODEL NUMBER PATTERN
□□□□□□□□□□ - □□□□
XXXXXXXXXX-XXX

Electrical

Impedance	50ohm
Frequency Range	0 to 18 GHz for RG-402 & RG-405 semi-rigid cable-0 to 18.0 GHz for flexible cable: 0 - 12.4 GHz
VSWR	RG-402(.141"OD) → 1.05+0.01 x f GHz max (Straight) 1.10+0.01 x f GHz max (Right Angle) RG-405(.085"OD) → 1.05+0.01 x f GHz max (Straight) 1.10+0.01 x f GHz max (Right Angle) RG-58,141,142,223 → 1.20+0.01 x f GHz max (Straight) 1.25+0.02 x f GHz max (Right Angle) RG-174,188,316 → 1.20+0.025 x f GHz max (Straight) 1.25+0.025 x f GHz max (Right Angle) RG-178,196 → 1.25+0.025 x f GHz max (Straight) 1.30+0.025 x f GHz max (Right Angle)
Voltage Rating	375 volts peak
Dielectric Withstanding Voltage	1000 volts rms max
Contact Resistance	center contact = 2.0 Milliohms max Outer contact = 2.0 Milliohms max
RF Leskage	-60dB minimum
Insertion Loss	0.3dB max x \sqrt{f} GHz @ 6 GHz
Insulation Resistance	5000 Megaohms min

Mechanical & Environmental

Mating	1/4"-36threaded coupling
Durability	500 matings
Coupling Nut Retention	60 lbs min
Recommend Nut Mating Torque	8 inch-pounds
Cable Retention	RG-174,188,316→ 20 lbs min RG-58,141,142,223→ 40 lbs min
Temperature Range	-65 °C to 165 °C
Vibration	MIL-STD-202 Method 204 Test Cond.B.
Salt Spray	MIL-STD-202 Method 201 Test Cond.B.
Temperature Cycling	MIL-STD-202 Method 107 Test Cond.B.

Material

	Material	Plating
Connector Body	Brass	Gold or Nickel
Center Contact	Male:Beryllium Copper Female:Brass	Gold Gold
Insulation	Teflon	None
Gasket	Silicone Rubber,Rubber	None
Crimp Ferrule	Annealed Copper	Same as Body

Interface Mating Dimensions

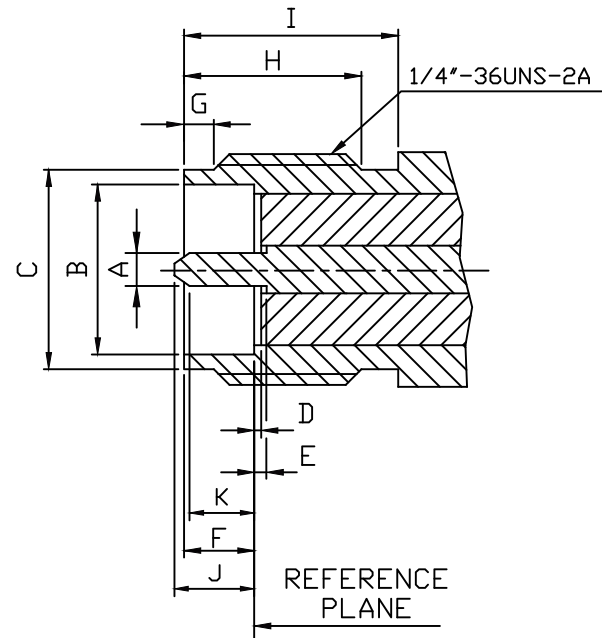
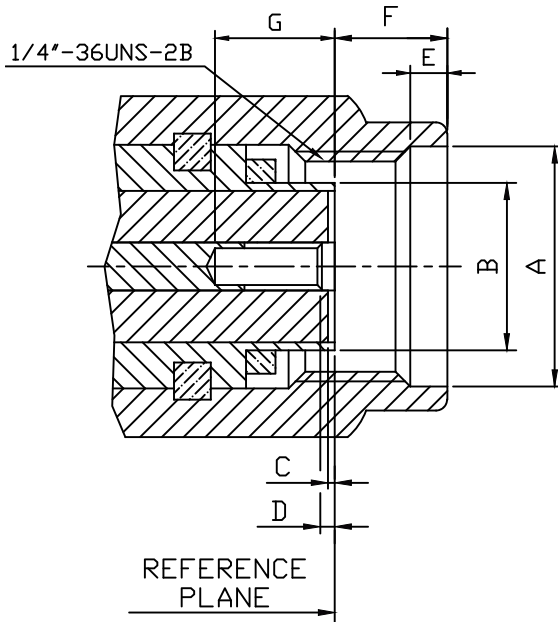

PLUG

JACK

Letter	Millimeters (Inches)	
	Minimum	Maximum
A	6.35 (.250)	-
B	-	4.59 (.1808)
C	0.00 (.000)	0.25 (.010)
D	0.00 (.000)	0.25 (.010)
E	0.38 (.015)	1.14 (.045)
F	-	3.43 (.135)
G	2.92 (.115)	-

Letter	Millimeters (Inches)	
	Minimum	Maximum
A	0.90 (.0355)	0.94 (.037)
B	4.60 (.1810)	-
C	5.28 (.208)	5.49 (.216)
D	0.00 (.000)	0.25 (.010)
E	0.00 (.000)	0.25 (.010)
F	1.88 (.074)	1.98 (.078)
G	0.38 (.015)	1.14 (.045)
H	4.32 (.170)	-
I	5.54 (.218)	-
J	-	2.54 (.100)
K	1.27 (.050)	-



**SMA Straight Bulkhead Jack
Reverse Polarity Crimp**

MODEL 4R19071B01
CABLE $\phi 1.13/\phi 1.32$
 $\phi 1.37/\text{RG178U}$

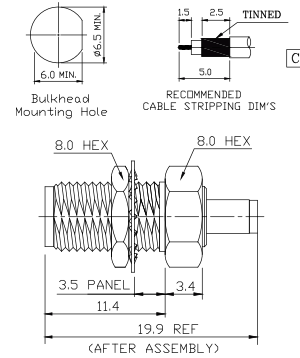

**SMA Straight Bulkhead Jack
Reverse Polarity Crimp**

MODEL 4R19071B06
CABLE RG174U/RG316

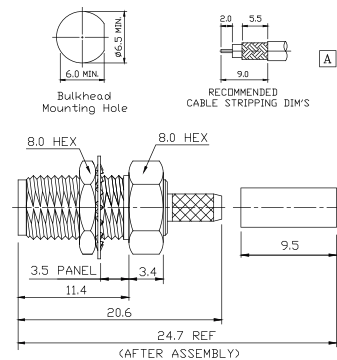

**SMA Straight Bulkhead Jack
Reverse Polarity Crimp**

MODEL 4R19101B01
CABLE $\phi 1.13/\phi 1.32$
 $\phi 1.37/\text{RG178U}$

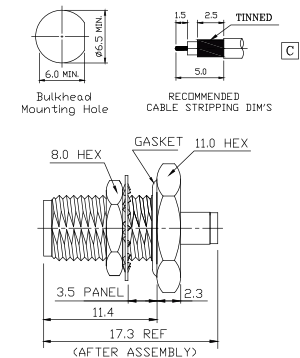

**SMA Straight Bulkhead Jack
Reverse Polarity Crimp**

MODEL 4R19101B06
CABLE RG174U/RG316

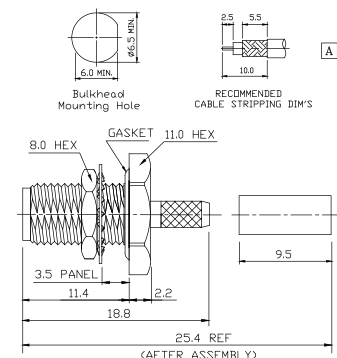



SMA Straight Plug Reverse Polarity Crimp

MODEL 4R19011B01
CABLE ϕ 1.13/ ϕ 1.32
 ϕ 1.37/RG178U

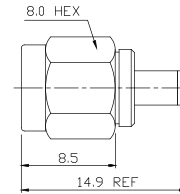
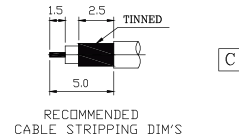

SMA Straight Plug Reverse Polarity Crimp

MODEL 4R19011B06
CABLE RG174U/RG316

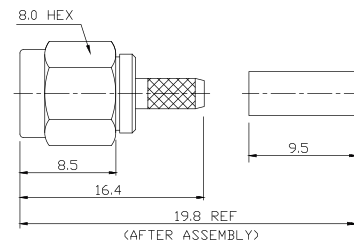
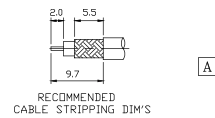

SMA Straight Plug Reverse Polarity Crimp

MODEL 4R19011B21
CABLE RG58U/RG142U

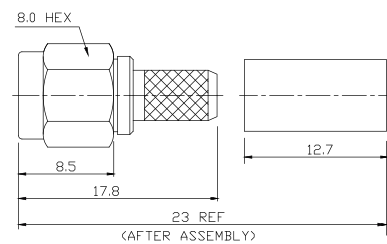
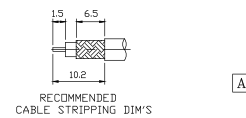

SMA Straight Plug Reverse Polarity Crimp

MODEL 4R19011B16
CABLE LMR400

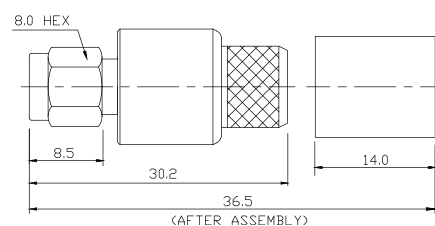
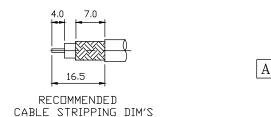



SMA Right Angle Jack Reverse Polarity PCB Mount Crimp

MODEL 4R1904PB01
CABLE $\phi 1.13/\phi 1.32$
 $\phi 1.37/\text{RG178U}$

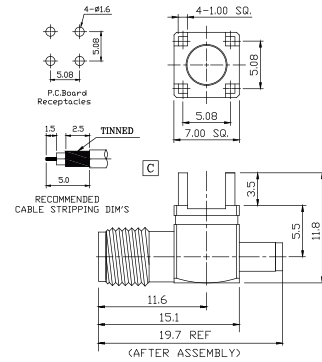

SMA Straight Jack Reverse Polarity Crimp

MODEL 4R19031B01
CABLE $\phi 1.13/\phi 1.32$
 $\phi 1.37/\text{RG178U}$

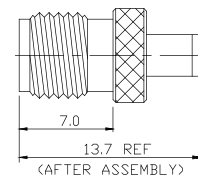
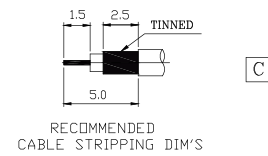

SMA Straight Jack Reverse Polarity Crimp

MODEL 4R19031B06
CABLE RG174U/RG316

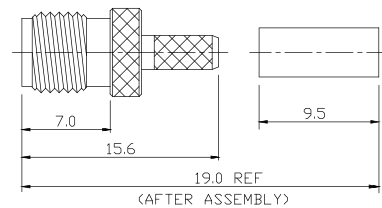
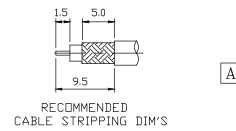

SMA Straight Jack Reverse Polarity Crimp

MODEL 4R19031B21
CABLE RG58U/RG142U

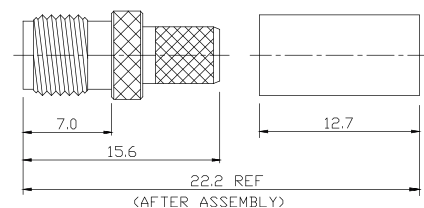
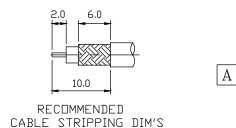



SMA Right Angle Plug
Reverse Polarity Crimp

MODEL 4R19021B01
CABLE $\phi 1.13/\phi 1.32$
 $\phi 1.37/\text{RG178U}$

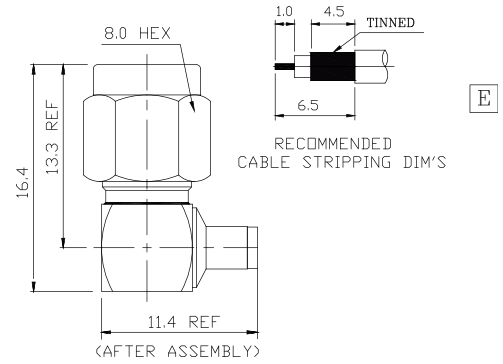

SMA Right Angle Plug
Reverse Polarity Crimp

MODEL 4R19021B06
CABLE RG174U/RG316

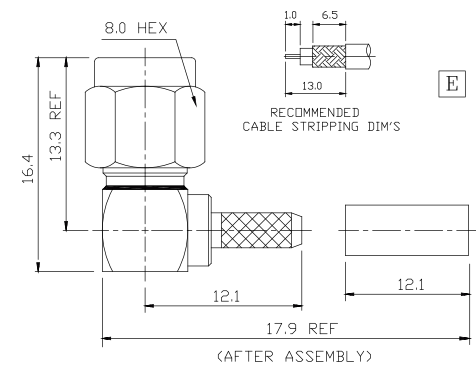

SMA Right Angle Plug
Reverse Polarity Crimp

MODEL 4R19021B21
CABLE RG58U

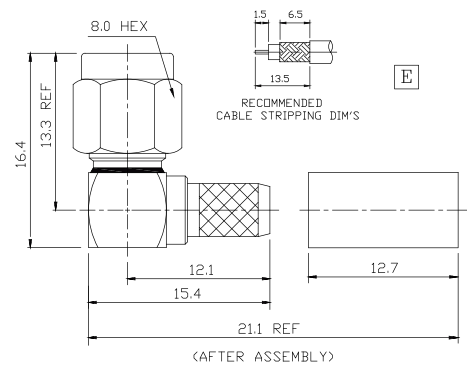

SMA Right Angle Jack
Reverse Polarity PCB Mount

MODEL 4R1904PBPM
CABLE PCB Mount

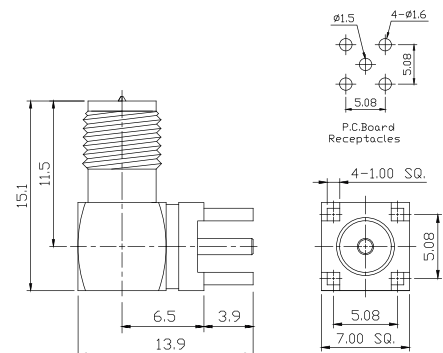



SMA Straight Jack Reverse Polarity Crimp

MODEL 4R19031B16

CABLE LMR400

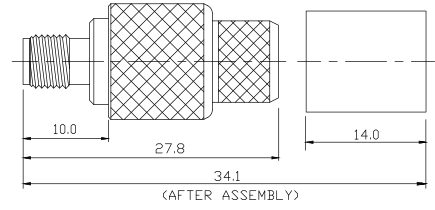
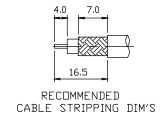

SMA-Series
N-Series

MCX-Series
MMCX-Series

TNC-Series
BNC-Series

Product Specs Chart

SMB-Series
ADAPTER
Light

LightningArrestor-Series ANTENNA-Series



MODEL NUMBER PATTERN

□□□□□□□□□□ - □□□□
XXXXXXXXXX-XXX

Electrical

Impedance	50ohm
Frequency Range	0 to 11GHz
VSWR	Straight : 1.3max ; Right Angle : 1.5max
Voltage Rating	1500 volts rms max
Dielectric Withstanding Voltage	2500 volts rms max
Contact Resistance	Center contact=1.0 Milliohms max Outer contact=1.0 Milliohms max
RF Leskage	-90dB
Insertion Loss	0.15dB max at 10 GHz
Insulation Resistance	5000 Megaohms min

Mechanical & Environmental

Mating	5/8"-24 threaded coupling
Durability	500 matings min
Coupling Nut Retention	100 lbs min
Cable Retention	RG-174,188,316→ 20 lbs min RG-58,141,142,223→ 40 lbs min RG-59,62A,210→ 40 lbs min RG-8A,9B,213,214→ 80 lbs min
Temperature Range	-65 °C to 165 °C
Vibration	MIL-STD-202 Method 204 Test Cond.B.
Salt Spray	MIL-STD-202 Method 201 Test Cond.B.
Temperature Cycling	MIL-STD-202 Method 107 Test Cond.B.

Material

	Material	Plating
Connector Body	Brass	Gold or Nickel or Silver
Center Contact	Male:Brass Female:Brass,Phosphor Bronze or Beryllium Copper	Gold Gold
Insulation	Teflon	None
Gasket	Silicone Rubber,Rubber	None
Crimp Ferrule	Annealed Copper or Brass	Same as Body

Interface Mating Dimensions

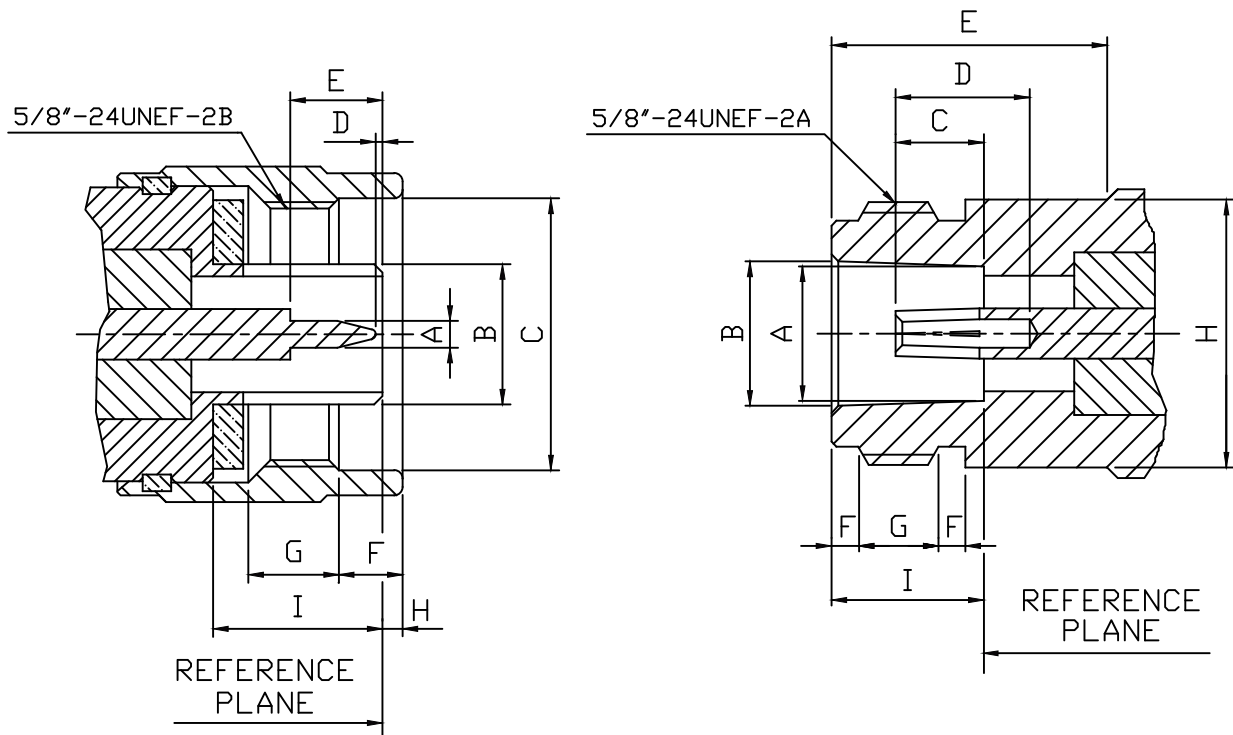

PLUG

JACK

Letter	Millimeters (Inches)	
	Minimum	Maximum
A	1.60 (.063)	1.68 (.066)
B	-	8.38 (.330)
C	16.00(.630)	-
D	0.08 (.003)	-
E	5.33 (.210)	5.84 (.230)
F	4.01 (.158)	4.27 (.168)
G	4.50 (.177)	-
H	0.41 (.016)	1.52 (.060)
I	10.11 (.398)	10.46 (.412)

Letter	Millimeters (Inches)	
	Minimum	Maximum
A	8.03 (.316)	8.13 (.320)
B	8.53 (.336)	8.74 (.344)
C	4.75 (.187)	5.26 (.207)
D	5.33 (.210)	-
E	10.72 (.422)	-
F	1.19 (.047)	1.96 (.077)
G	4.37 (.172)	5.13 (.202)
H	-	15.93 (.627)
I	9.04 (.356)	9.19 (.362)



N Straight Plug Crimp

MODEL 4B11011A01
CABLE ϕ 1.13/ ϕ 1.32
 ϕ 1.37/RG178U

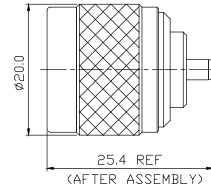
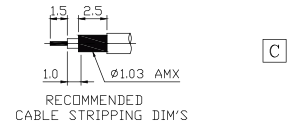

N Straight Plug Crimp

MODEL 4B11011A06
CABLE RG174U/RG316U

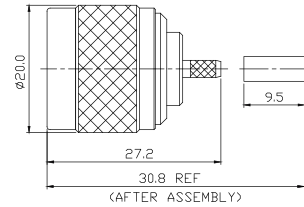
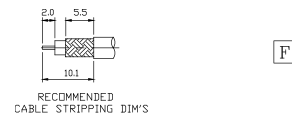

N Straight Plug Crimp

MODEL 4B11011A21
CABLE RG58U/RG142U

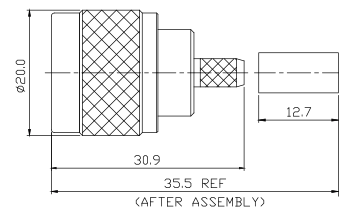
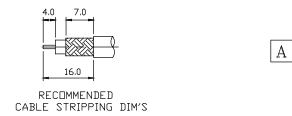

N Straight Plug Crimp

MODEL 4B11011A16
CABLE LMR400

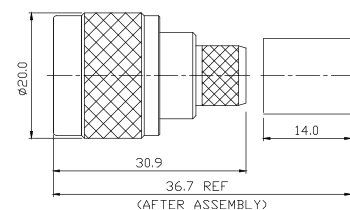
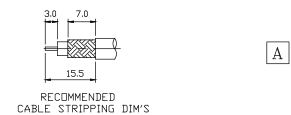



N Straight Plug Crimp

MODEL 4B11011A17

CABLE LMR600

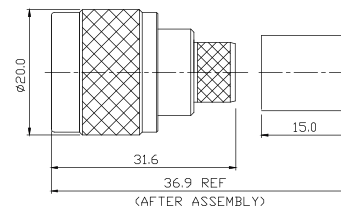
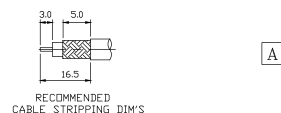

N Right Angle Plug Crimp

MODEL 4B11021A06

CABLE RG174U/RG316U

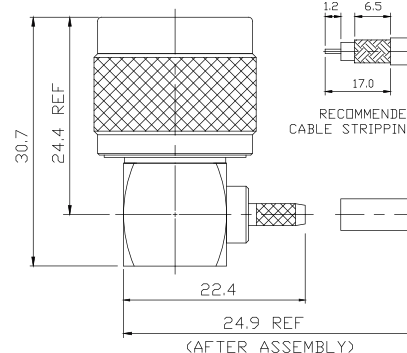
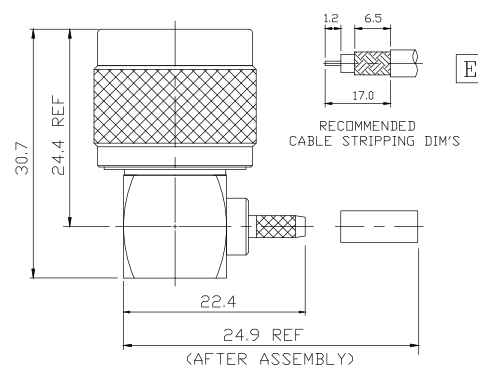

N Right Angle Plug Crimp

MODEL 4B11021A21

CABLE RG58U/RG142U

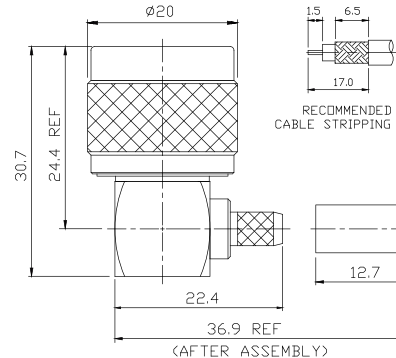
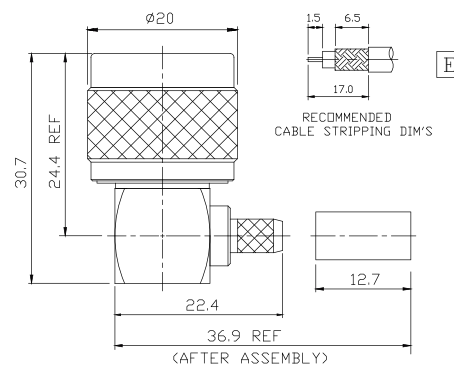

N Right Angle Plug Crimp

MODEL 4B11021A16

CABLE LMR400

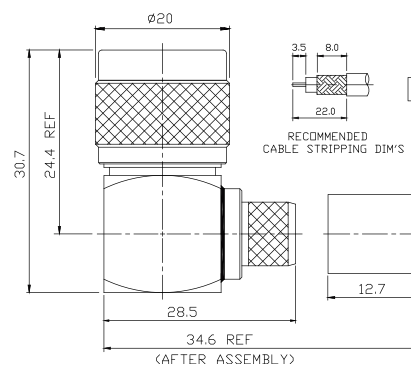
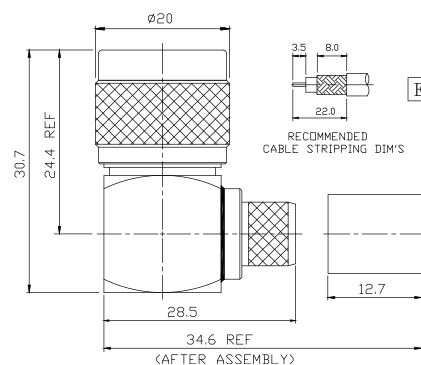



N Straight Plug Clamp

MODEL 4B11012A21
CABLE RG58U/RG142U

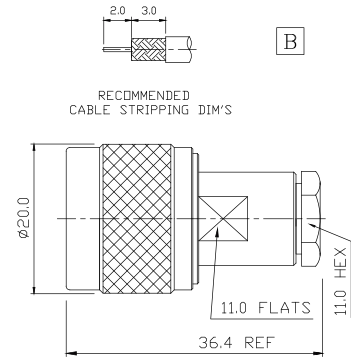

N Straight Plug Clamp

MODEL 4B11012A16
CABLE LMR400

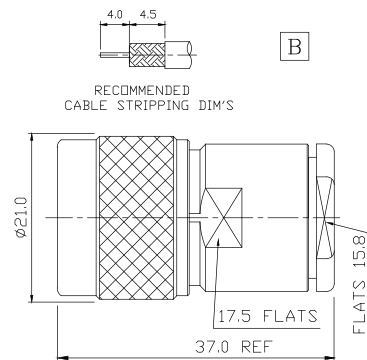

N Straight Jack Crimp

MODEL 4B11031A01
CABLE $\phi 1.13/\phi 1.32$
 $\phi 1.37$ /RG178U

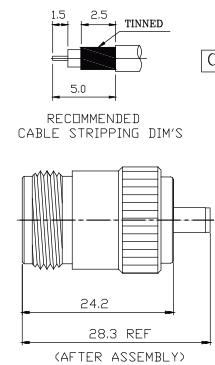

N Straight Jack Crimp

MODEL 4B11031A06
CABLE RG174/RG316

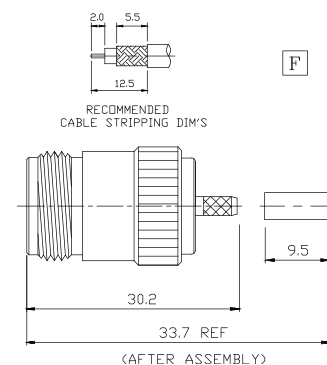



N Straight Jack Crimp

MODEL 4B11031A21
CABLE RG58U/RG142U

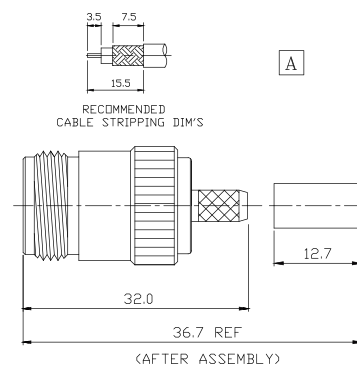

N Straight Jack Crimp

MODEL 4B11031A16
CABLE LMR400

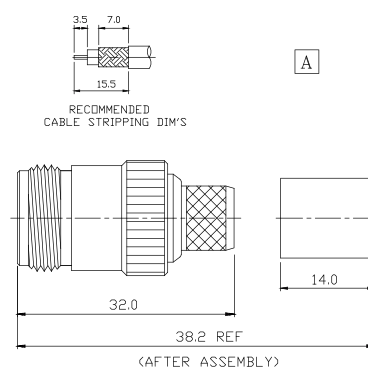

N Straight Jack Crimp

MODEL 4B11031A17
CABLE LMR600

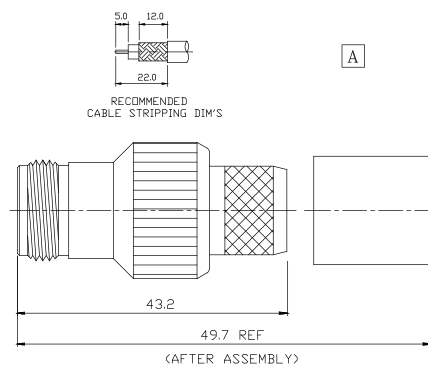

N Straight Bulkhead Jack Crimp

MODEL 4B11071A01
CABLE $\phi 1.13/\phi 1.32$
 $\phi 1.37/\text{RG178U}$

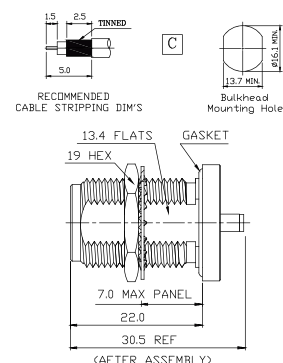



N Straight Bulkhead Jack Crimp

MODEL 4B11071A06
CABLE RG174U/RG316U

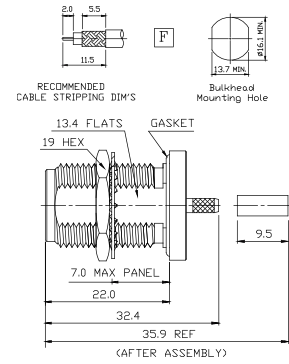

N Straight Bulkhead Jack Crimp

MODEL 4B11071A21
CABLE RG58U/RG142U

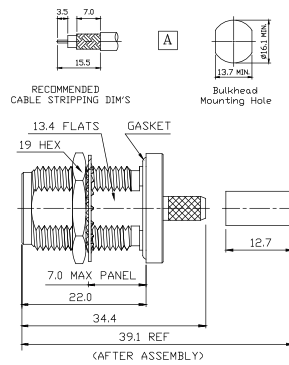

N Straight Bulkhead Jack Crimp

MODEL 4B11071A16
CABLE LMR400

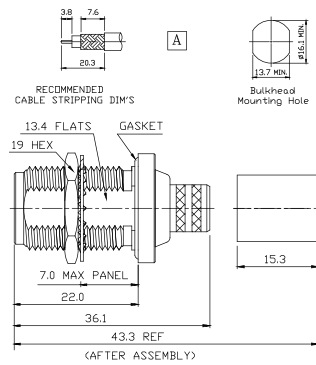

N Straight Bulkhead Jack Crimp

MODEL 4B11071A18
CABLE RG405U/RG402U

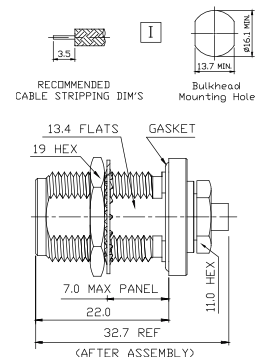



N Jack Straight Panel Mount Receptacle

MODEL 4B1103PAPR

CABLE Panel Mount

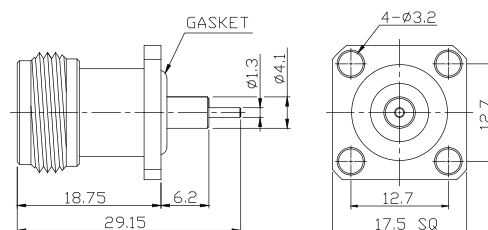

N Jack Straight Panel Mount Receptacle

MODEL 4B1103PAPR

CABLE Panel Mount

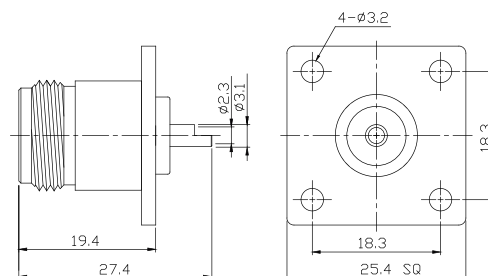

N Straight Jack Clamp

MODEL 4B11032A16

CABLE LMR400

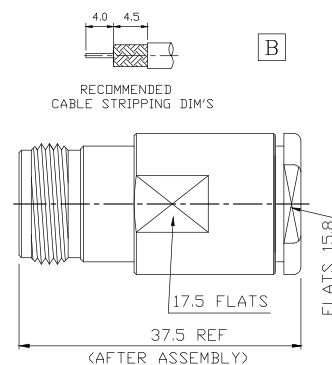

SMA-Series
N-Series

MCX-Series

MMCX-Series
TNC-Series

Product Specs Chart

BNC-Series
SMB-Series
ADAPTER
Light

LightningArrestor-Series ANTENNA-Series



MODEL NUMBER PATTERN
□□□□□□□□□□ - □□□□
XXXXXXXXXX-XXX

Electrical

Impedance	50ohm
Frequency Range	0 to 6 GHz
VSWR	0-2 GHz 1.22 max (Straight) 1.50 max (Right Angle)
	2-6 GHz 1.35 max (Straight) 1.65 max (Right Angle)
Voltage Rating	355 volts rms max
Dielectric Withstanding Voltage	RG-174,188,316 → 750 volts rms max RG-178,196 → 500 volts rms max
Contact Resistance	Center contact=5.0 Milliohms max Outer contact=1.0 Milliohms max
RF Leskage	-60dB minimum
Insertion Loss	0.15 dB max (Straight) 0.6 dB max (Right Angle)
Insulation Resistance	1000 Megaohms min

Mechanical & Environmental

Mating	"Push-Pull" snap-on coupling
Durability	500 matings min
Cable Retention	RG-174,188,316 20 lbs min
Temperature Range	-65 °C to 165 °C
Vibration	MIL-STD-202 Method 204 Test Cond.B.
Salt Spray	MIL-STD-202 Method 201 Test Cond.B.
Temperature Cycling	MIL-STD-202 Method 107 Test Cond.B.

Material

	Material	Plating
Connector Body	Brass	Gold or Nickel
Center Contact	Male:Brass Female:Beryllium Copper	Gold Gold
Insulation	Teflon	None
Gasket	Silicone	None
Crimp Ferrule	Annealed Copper	Same as Body

Interface Mating Dimensions

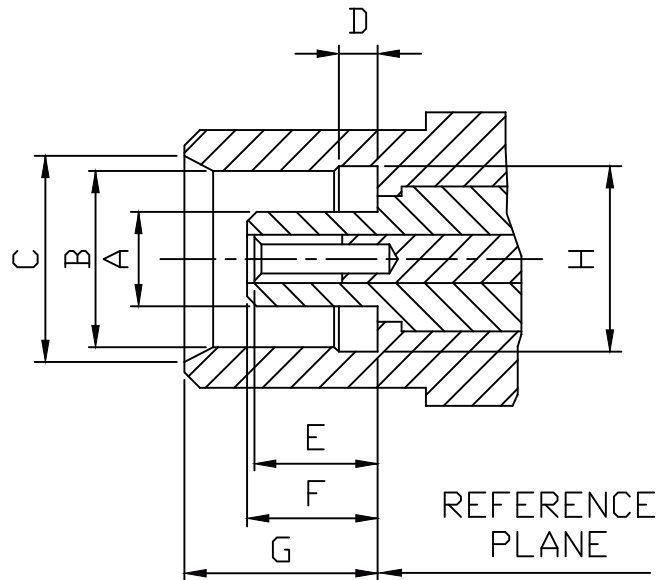
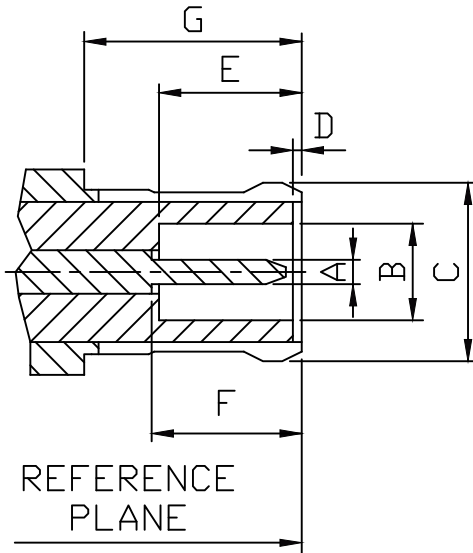

PLUG

Letter	Millimeters (Inches)	
	Minimum	Maximum
A	0.48 (.019)	0.53 (.021)
B	2.00 (.079)	-
C	-	3.81 (.150)
D	0.00 (.000)	0.30 (.012)
E	2.80 (.110)	-
F	2.80 (.110)	3.20 (.126)
G	4.15 (.163)	-

JACK

Letter	Millimeters (Inches)	
	Minimum	Maximum
A	-	1.98 (.078)
B	3.42 (.135)	3.48 (.137)
C	3.80 (.150)	-
D	0.75 (.030)	0.85 (.033)
E	2.30 (.090)	2.80 (.110)
F	2.60 (.102)	2.80 (.110)
G	4.00 (.157)	4.12 (.162)
H	3.60 (.142)	3.75 (.147)

MCX Straight Plug Crimp



MODEL 4B23011B01
CABLE ϕ 1.13/ ϕ 1.32
 ϕ 1.37/RG178U

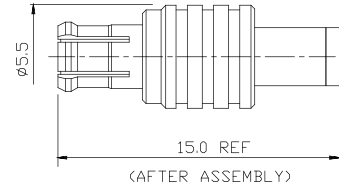
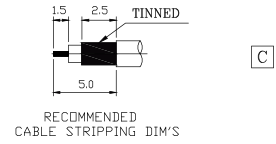

MCX Straight Plug Crimp



MODEL 4B23011B06
CABLE RG174U/RG316U

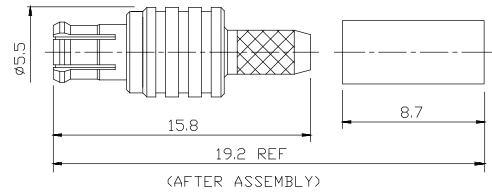
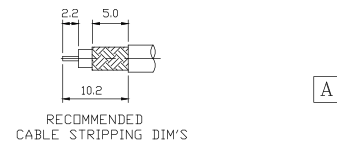

MCX Straight Plug Crimp



MODEL 4B23011B21
CABLE RG58U/RG142U

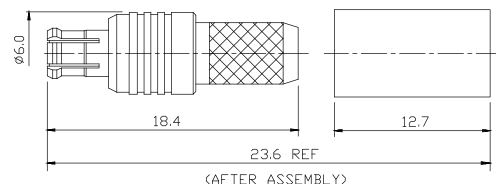
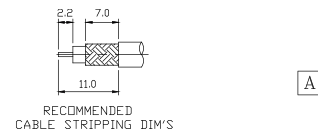

MCX Straight Plug Crimp



MODEL 4B23011B18
CABLE RG405

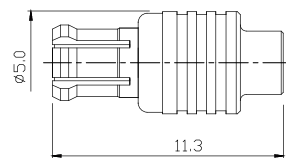
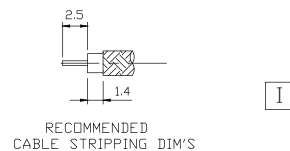



MCX Right Angle Piug Crimp

MODEL 4B23021B05

CABLE RG178

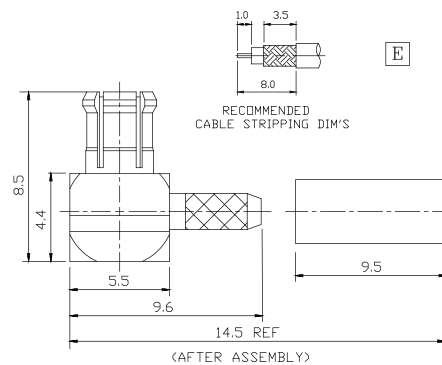

MCX Right Angle Piug Crimp

MODEL 4B23021B06

CABLE RG174/RG316U

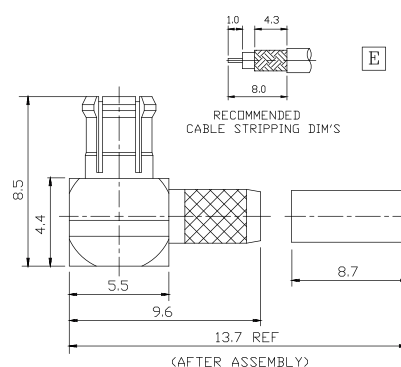

MCX Right Angle Piug Crimp

MODEL 4B23021B21

CABLE RG58U/RG142U

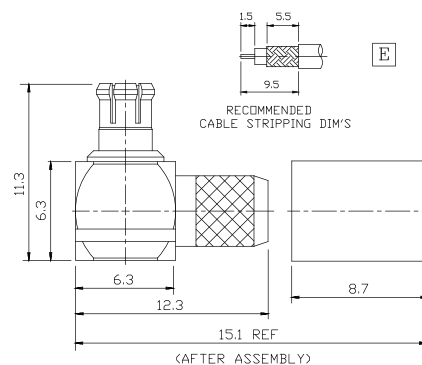

MCX Right Angle Piug Crimp

MODEL 4B23021B18

CABLE RG405

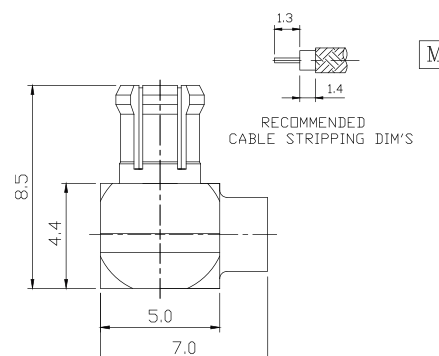



MCX Straight Plug PCB Mount

MODEL 4B2301PBPM
CABLE PCB Mount

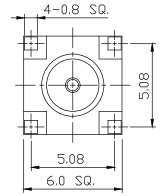
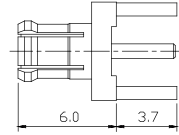
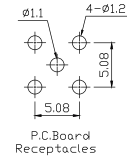

MCX Straight Jack PCB Mount

MODEL 4B2303PBPM
CABLE PCB Mount

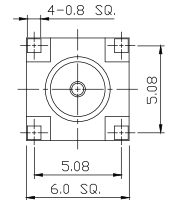
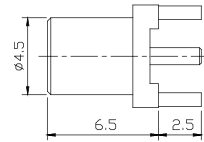
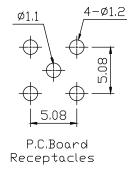

MCX Straight Jack PCB SMT

MODEL 4B2303PBSPM
CABLE Surface Mount

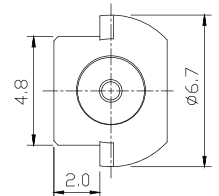
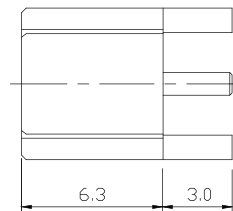

MCX Right Angle Plug PCB Mount

MODEL 4B2302PBPM
CABLE PCB Mount

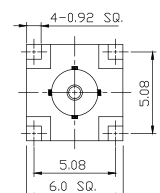
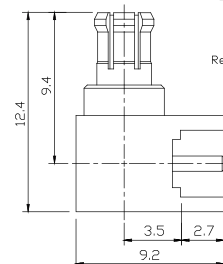
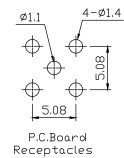



MCX Right Angle Jack PCB Mount

MODEL 4B2304PBPM
CABLE PCB Mount

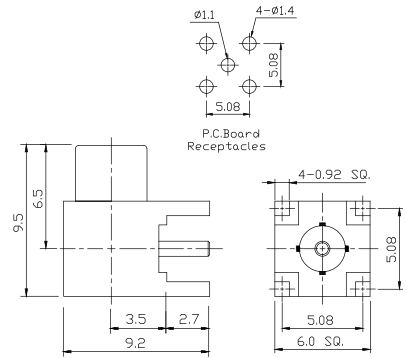

MCX Right Angle Jack Crimp

MODEL 4B23041B06
CABLE RG174U/RG316U

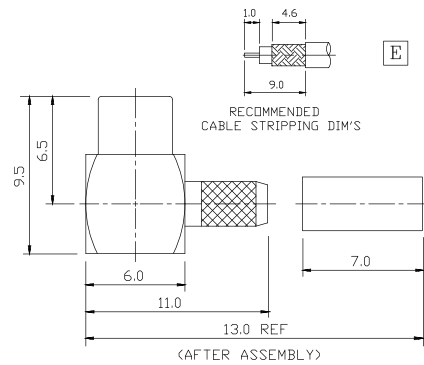

MCX Straight Jack Crimp

MODEL 4B23031B01
CABLE $\phi 1.13/\phi 1.32$
 $\phi 1.37$ /RG178U

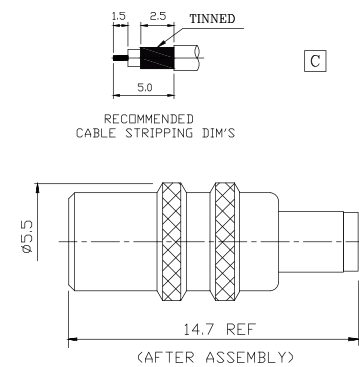

MCX Straight Bulkhead Jack Crimp

MODEL 4B23071B01
CABLE $\phi 1.13/\phi 1.32$
 $\phi 1.37$ /RG178U

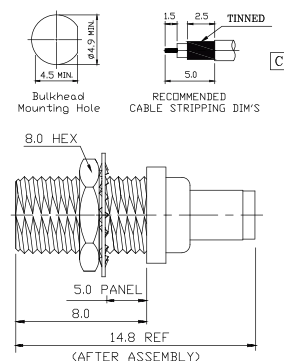



MCX Straight Bulkhead Jack Crimp

MODEL 4B23071B06

CABLE RG174U/RG316U

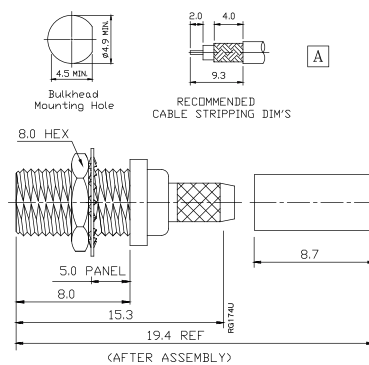

SMA-Series

N-Series

MCX-Series

MMCX-Series

TNC-Series

BNC-Series

SMB-Series

ADAPTER

Light

Product Specs Chart

LightningArrestor-Series ANTENNA-Series



MODEL NUMBER PATTERN

□□□□□□□□□□ - □□□□
XXXXXXXXXX-XXX

Electrical

Impedance	50ohm
Frequency Range	0 to 6 GHz
VSWR	Straight : 1.25 max ; Right Angle : 1.35 max
Working Voltage	170 volts rms max
Dielectric Withstanding Voltage	Voltage 500 volts rms max
Contact Resistance	Center contact = 10 Milliohms max Outer contact = 5 Milliohms max

Mechanical & Environmental

Mating	snap-on coupling
Durability	500 matings min
Cable Retention	RG-174,188,316 → 15 lbs min RG-178 → 6 lbs min
Temperature Range	-65 °C to 165 °C
Vibration	MIL-STD-202 Method 204 Test Cond.D.
Salt Spray	MIL-STD-202 Method 201 Test Cond.B.
Temperature Cycling	MIL-STD-202 Method 107

Material

	Material	Plating
Connector Body	Brass	Gold or Nickel
Center Contact	Male:Brass Female:Beryllium Copper	Gold Gold
Insulation	Teflon	None
Gasket	Silicone	None
Crimp Ferrule	Annealed Copper	Same as Body

Interface Mating Dimensions

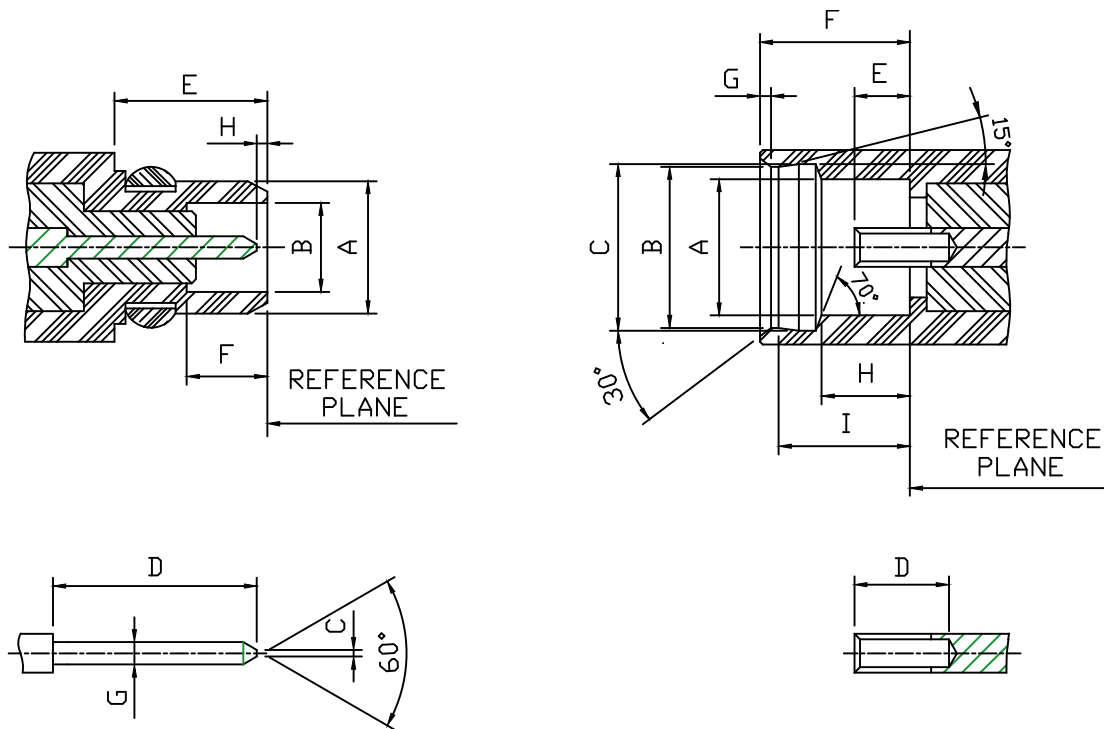

PLUG

JACK

Letter	Millimeters(Inches)	
	Minimum	Maximum
A	—	2.40(.094)
B	1.58(.062)	1.62(.064)
C	—	0.20(.008)
D	—	3.15(.124)
E	2.70(.106)	—
F	1.45(.057)	—
G	0.38(.015)	0.42(.017)
H	0.00(.000)	0.25(.010)

Letter	Millimeters(Inches)	
	Minimum	Maximum
A	2.41(.095)	—
B	2.88(.113)	2.90(.114)
C	3.00(.118)	3.04(.120)
D	1.40(.055)	—
E	0.90(.035)	1.20(.047)
F	2.60(.102)	—
G	—	0.23(.009)
H	1.57(.062)	1.63(.064)
I	2.30(.091)	2.34(.092)



MMCX Right Angle Plug Crimp

MODEL 4B26021B05
CABLE RG178U

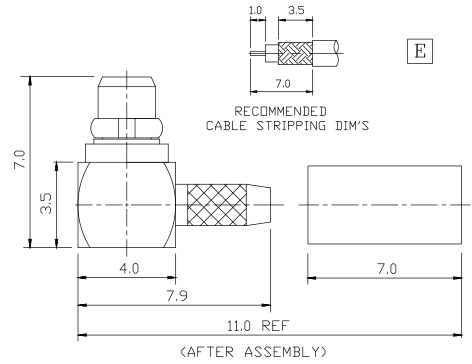

MMCX Right Angle Plug Crimp

MODEL 4B26021B06
CABLE RG174U/RG316U

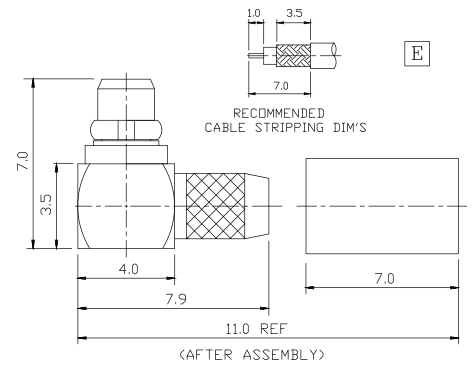

MMCX Straight Plug Crimp

MODEL 4B26011B01
CABLE ϕ 1.13/ ϕ 1.32
 ϕ 1.37/RG178U

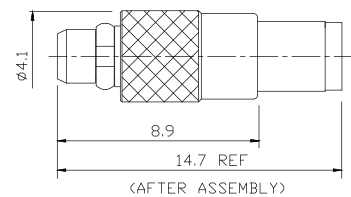
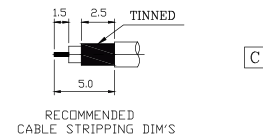

MMCX Straight Plug Crimp

MODEL 4B26011B06
CABLE RG174U/RG316U

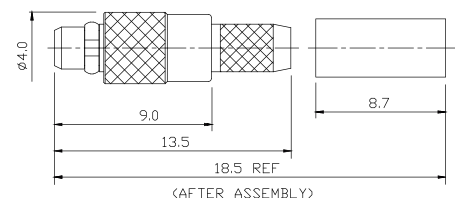
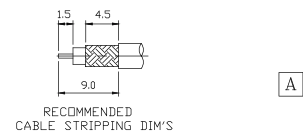



MMCX Straight Jack PCB Mount

MODEL 4B2603PBPM
CABLE PCB Mount

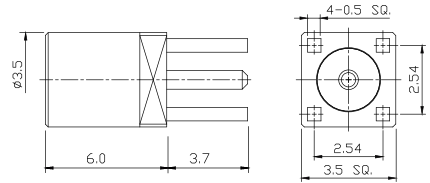
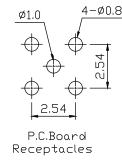

MMCX Straight Jack Surface Mount

MODEL 4B2603PBSM
CABLE Surface Mount

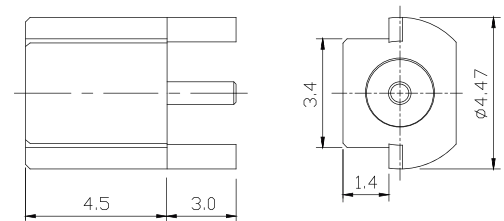

MMCX Straight Jack Crimp

MODEL 4B26031B06
CABLE RG174U/RG316U

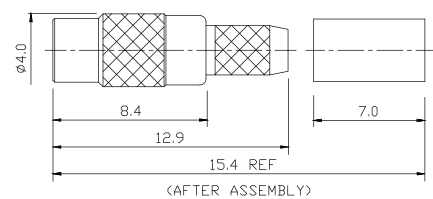
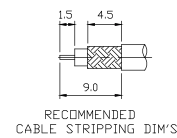

MMCX Straight Plug Edge Card Receptacle

MODEL 4B2601PBSM
CABLE Surface Mount

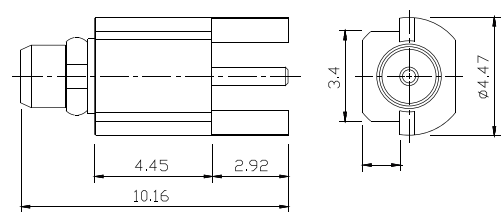



MMCX Straight Jack Crimp

MODEL 4B26071B06

CABLE RG174U/RG316U

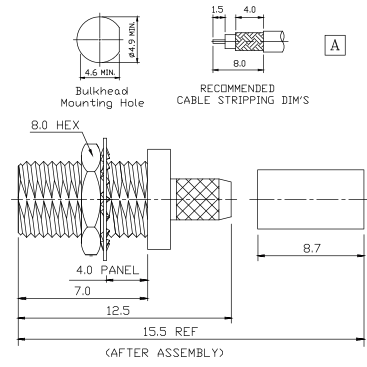

MMCX Straight Plug PCB Mount

MODEL 4B2601PBPM

CABLE PCB Mount

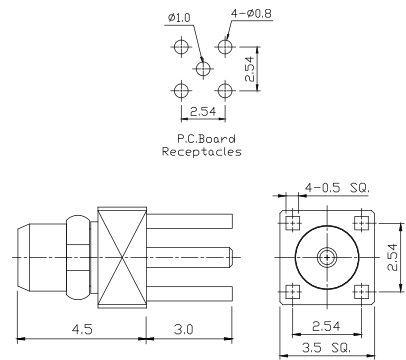

SMA-Series

N-Series

MCX-Series

MMCX-Series

TNC-Series

Product Specs Chart

BNC-Series

SMB-Series

ADAPTER

Light

LightningArrestor-Series ANTENNA-Series



MODEL NUMBER PATTERN
□□□□□□□□□□ - □□□□
XXXXXXXXXX-XXX

Electrical

Impedance	50ohm
Frequency Range	0 to 11 GHz
VSWR	Straight : 1.3 max ; Right Angle : 1.35 max
Voltage Rating	500 volts rms max
Dielectric Withstanding Voltage	1500 volts rms max
Contact Resistance	Center contact = 1.5 Milliohms max Outer contact = 0.5 Milliohms max
RF Leakage	-60 dB minimum at 3 GHz
Insertion Loss	0.2 dB max at 3 GHz
Insulation Resistanec	5000 Megaohms min

Mechanical & Environmental

Mating	7/16"-28 threaded coupling
Durability	500 matings min
Coupling Nut Retention	100 lbs min
Cable Retention	RG-174,188,316 → 20 lbs min RG-58,141,142,223 → 40 lbs min RG-59,62A,210 → 40 lbs min RG-8A,9B,213,214 → 80 lbs min
Temperature Range	-65 °C to 165 °C
Vibration	MIL-STD-202 Method 204 Test Cond.B.
Salt Spray	MIL-STD-202 Method 201 Test Cond.B.
Temperature Cycling	MIL-STD-202 Method 107 Test Cond.B.

Material

	Material	Plating
Connector Body	Brass	Gold or Nickel or Silver
Center Contact	Male:Brass Female:Brass,phosphor Bronze or Beryllium Copper	Gold Gold
Insulation	Teflon	None
Gasket	Silicone Rubber,Rubber	None
Crimp Ferrule	Annealed Copper or Brass	Same as Body

Interface Mating Dimensions

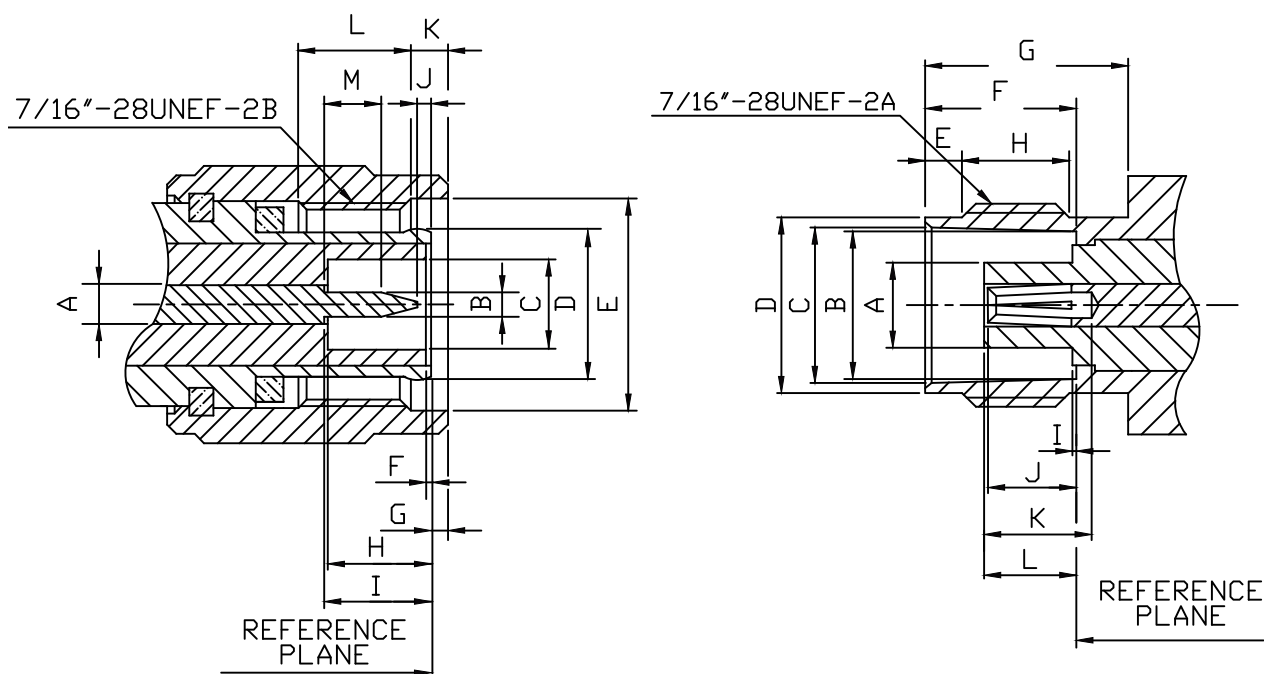

PLUG

Letter	Millimeters (Inches)	
	Minimum	Maximum
A	2.06(.081)	2.21(.087)
B	1.32(.052)	1.37(.054)
C	4.83(.190)	-
D	SLOTTED AND FLARED TO MEET ELECTRICAL AND MECHANICAL REQUIREMENTS	
E	11.18(.440)	-
F	0.15(.006)	-
G	-	1.98(.078)
H	5.28(.208)	5.79(.228)
I	5.33(.210)	5.84(.230)
J	0.08(.003)	1.02(.040)
K	1.60(.063)	-
L	3.96(.156)	-
M	1.98(.078)	-

JACK

Letter	Millimeters (Inches)	
	Minimum	Maximum
A	-	4.72(.186)
B	8.10(.319)	8.15(.321)
C	8.31(.327)	8.46(.333)
D	9.60(.378)	9.68(.381)
E	1.73(.068)	2.24(.088)
F	8.31(.327)	8.51(.335)
G	10.52(.414)	-
H	4.75(.187)	-
I	-	0.15(.006)
J	4.72(.186)	5.23(.206)
K	4.95(.195)	-
L	4.78(.188)	5.28(.208)



TNC Straight Plug Crimp

MODEL 4B13011A01
CABLE ϕ 1.13/ ϕ 1.32
 ϕ 1.37/RG178U

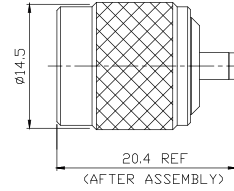
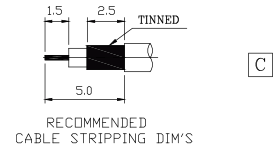

TNC Straight Plug Crimp

MODEL 4B13011A06
CABLE RG174U/RG316U

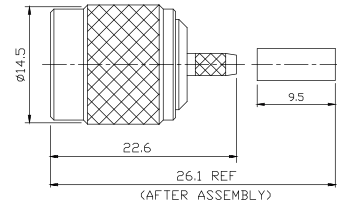
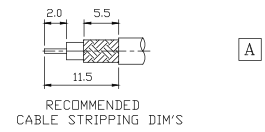

TNC Straight Plug Crimp

MODEL 4B13011A21
CABLE RG58U/RG142U

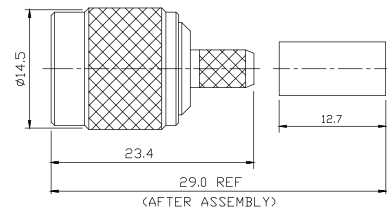
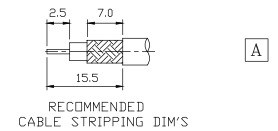

TNC Straight Plug Crimp

MODEL 4B13011A16
CABLE LMR400

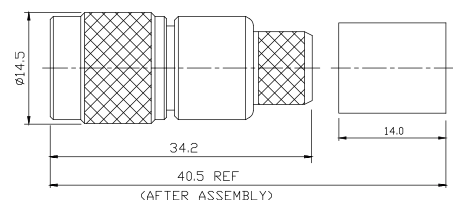
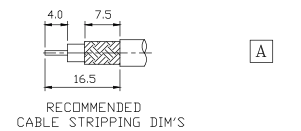



TNC Right Angle Plug Crimp

MODEL 4B13021A06
CABLE RG-174U/RG316U

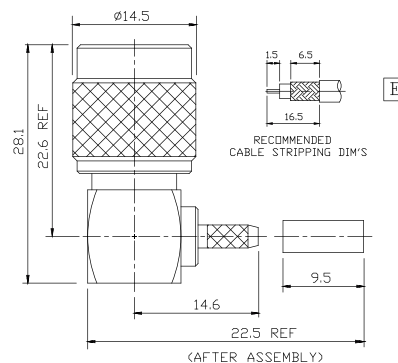

TNC Right Angle Plug Crimp

MODEL 4B13021A21
CABLE RG-58U/RG142U

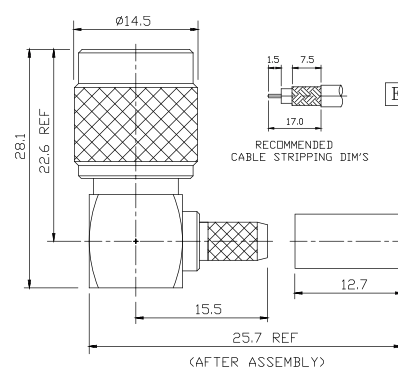

TNC Straight Jack Crimp

MODEL 4B13031A06
CABLE RG174U/RG316U

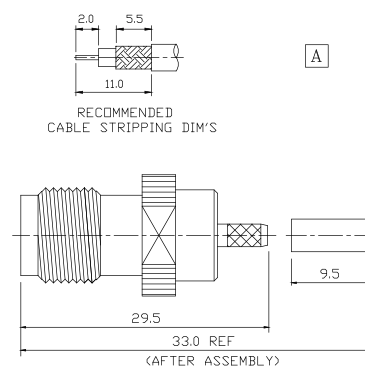

TNC Straight Bulkhead Jack Crimp

MODEL 4B13101A06
CABLE RG174U/RG316U

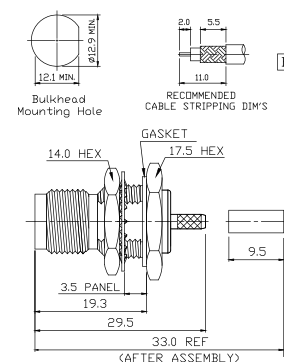

SMA-Series

N-Series

MCX-Series

MMCX-Series

RP TNC-Series

Product Specs Chart

BNC-Series

SMB-Series

ADAPT

Light

LightningArrestor-Series ANTENNA-Series



MODEL NUMBER PATTERN
□□□□□□□□□□ - □□□□
XXXXXXXXXX-XXX

Electrical

Impedance	50ohm
Frequency Range	0 to 4 GHz
VSWR	Straight : 1.3 max ; Right Angle : 1.35 max
Voltage Rating	500 volts rms max
Dielectric Withstanding Voltage	1500 volts rms max
Contact Resistance	Center contact = 1.5 Milliohms max Outer contact = 0.5 Milliohms max
RF Leakage	-60 dB minimum at 3 GHz
Insertion Loss	0.2 dB max at 3 GHz
Insulation Resistanec	5000 Megaohms min

Mechanical & Environmental

Mating	7/16"-28 threaded coupling
Durability	500 matings min
Coupling Nut Retention	100 lbs min
Cable Retention	RG-174,188,316 → 20 lbs min RG-58,141,142,223 → 40 lbs min RG-59,62A,210 → 40 lbs min RG-8A,9B,213,214 → 80 lbs min
Temperature Range	-65 °C to 165 °C
Vibration	MIL-STD-202 Method 204 Test Cond.B.
Salt Spray	MIL-STD-202 Method 201 Test Cond.B.
Temperature Cycling	MIL-STD-202 Method 107 Test Cond.B.

Material

	Material	Plating
Connector Body	Brass	Gold or Nickel or Silver
Center Contact	Male:Brass Female:Brass,phosphor Bronze or Beryllium Copper	Gold Gold
Insulation	Teflon	None
Gasket	Silicone Rubber,Rubber	None
Crimp Ferrule	Annealed Copper or Brass	Same as Body

Interface Mating Dimensions

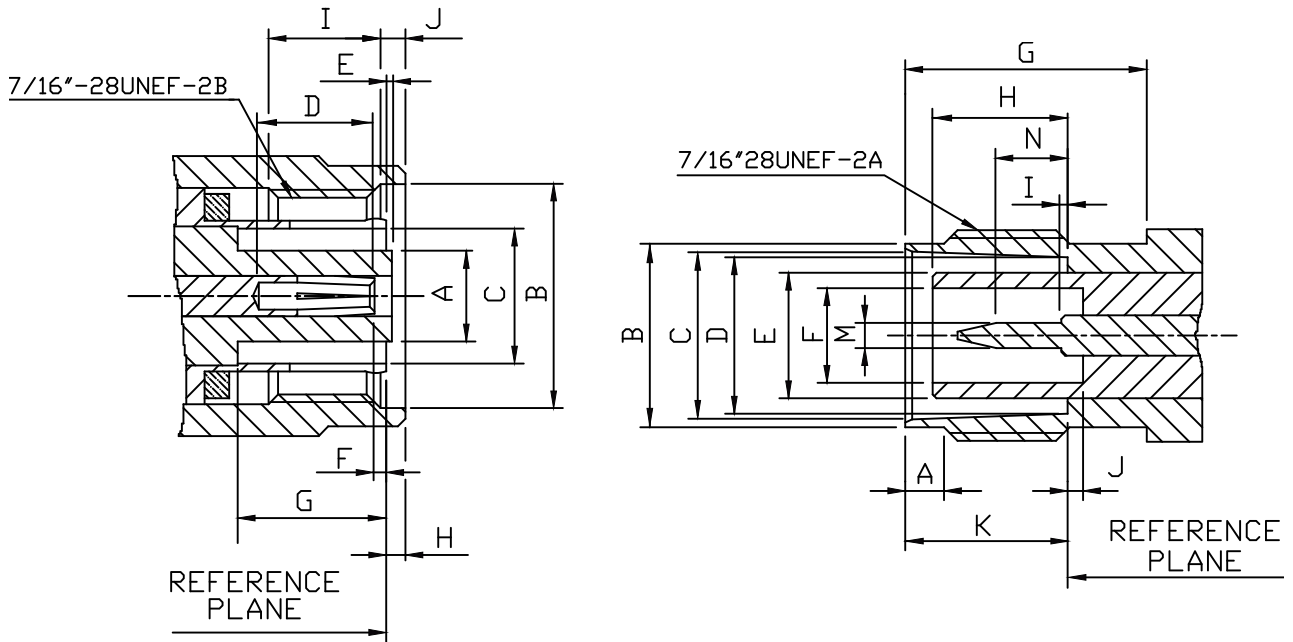

PLUG

Letter	Millimeters(Inches)	
	Minimum	Maximum
A	-	4.72(.186)
B	11.18(.440)	-
C	7.00(.276)	-
D	-	4.95(.195)
E	0.03(.001)	0.53(.021)
F	0.61(.024)	1.12(.044)
G	7.52(.296)	-
H	1.60(.063)	-
I	3.96(.156)	-
J	1.60(.063)	-

JACK

Letter	Millimeters(Inches)	
	Minimum	Maximum
A	1.73(.068)	2.24(.088)
B	9.60(.378)	9.68(.381)
C	8.31(.327)	8.46(.333)
D	8.10(.319)	8.15(.321)
E	-	6.65(.262)
F	4.83(.190)	-
G	10.52(.414)	-
H	4.78(.188)	5.28(.208)
I	0.00(.000)	0.25(.010)
J	0.53(.021)	1.04(.041)
K	8.31(.327)	8.51(.335)
M	1.32(.052)	1.37(.054)
N	1.98(.078)	-



TNC Straight Plug Reverse Polarity Crimp

MODEL 4R13011A06
CABLE RG174U/RG316U

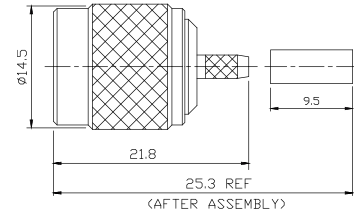
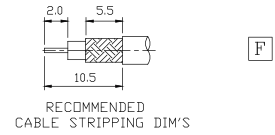

TNC Straight Plug Reverse Polarity Crimp

MODEL 4R13011A21
CABLE RG58U/RG142U

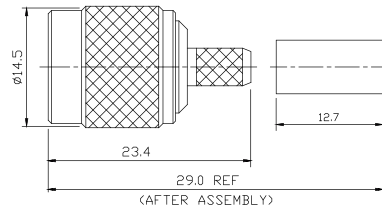
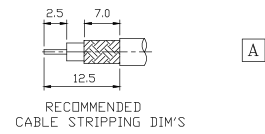

TNC Straight Plug Reverse Polarity Crimp

MODEL 4R13011A16
CABLE LMR400

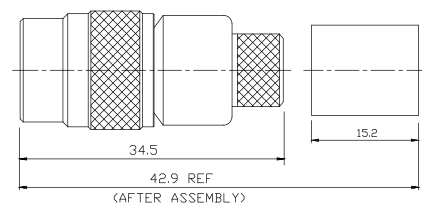
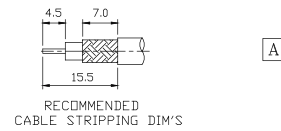

TNC Straight Plug Reverse Polarity Crimp

MODEL 4R13011A17
CABLE LMR600

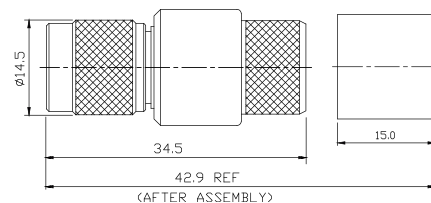
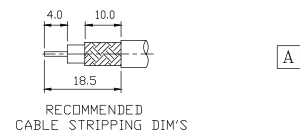



TNC Right Angle Plug Reverse Polarity Crimp

MODEL 4R13021A06
CABLE RG174U/RG316U

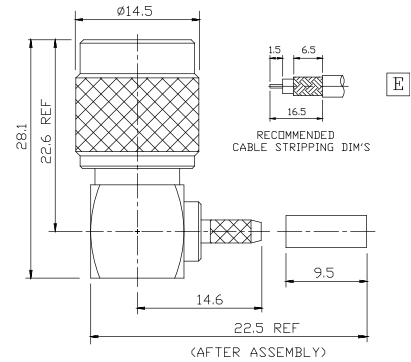

TNC Right Angle Plug Reverse Polarity Crimp

MODEL 4R13021A21
CABLE RG58U/RG142U

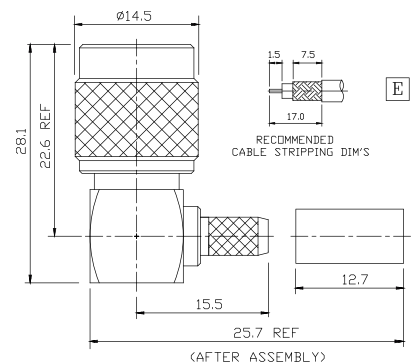

TNC Straight Jack Reverse Polarity Crimp

MODEL 4R13031A06
CABLE RG174U/RG316U

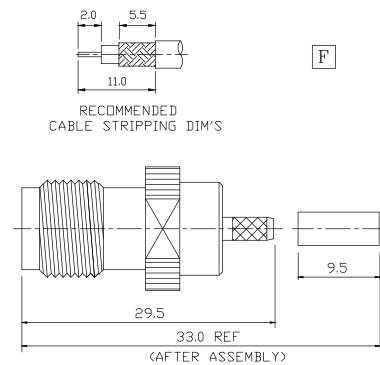

TNC Straight Bulkhead Jack Reverse Polarity Crimp

MODEL 4R13101A06
CABLE RG174U/RG316U

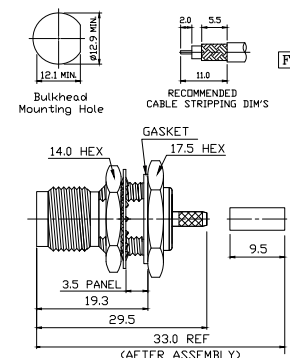

SMA-Series

N-Series

MCX-Series

MMCX-Series

TNC-Series

Product Specs Chart

BNC-Series

SMB-Series

ADAPTE

Light

A

LightningArrestor-Series ANTENNA-Series



MODEL NUMBER PATTERN

□□□□□□□□□□ - □□□□
XXXXXXXXXX-XXX

Electrical

Impedance	50ohm
Frequency Range	0 to 4 GHz
VSWR	Straight : 1.3 max ; Right Angle : 1.35 max
Voltage Rating	500 volts rms max
Dielectric Withstanding Voltage	1500 volts rms max
Contact Resistance	Center contact=1.5 Milliohms max Outer contact=0.5 Milliohms max
RF Leskage	-55dB minimum at 3 GHz
Insertion Loss	0.2dB max at 3 GHz
Insulation Resistance	5000 Megaohms min

Mechanical & Environmental

Mating	Two stud bayonet coupling
Durability	500 matings
Coupling Nut Retention	100 lbs min
Cable Retention	RG-174,188,316→ 20 lbs min RG-58,141,142,223→ 40 lbs min RG-59,62A,210→ 40 lbs min RG-8A,9B,213,214→ 80 lbs min
Temperature Range	-65 °C to 165 °C
Vibration	MIL-STD-202 Method 204 Test Cond.B.
Salt Spray	MIL-STD-202 Method 201 Test Cond.B.
Temperature Cycling	MIL-STD-202 Method 107 Test Cond.B.

Material

	Material	Plating
Connector Body	Brass	Gold or Nickel or Silver
Center Contact	Male:Brass Female:Brass,Phosphor Bronze or Beryllium Copper	Gold Gold
Insulation	Teflon	None
Gasket	Silicone Rubber,Rubber	None
Crimp Ferrule	Annealed Copper or Brass	Same as Body

Interface Mating Dimensions

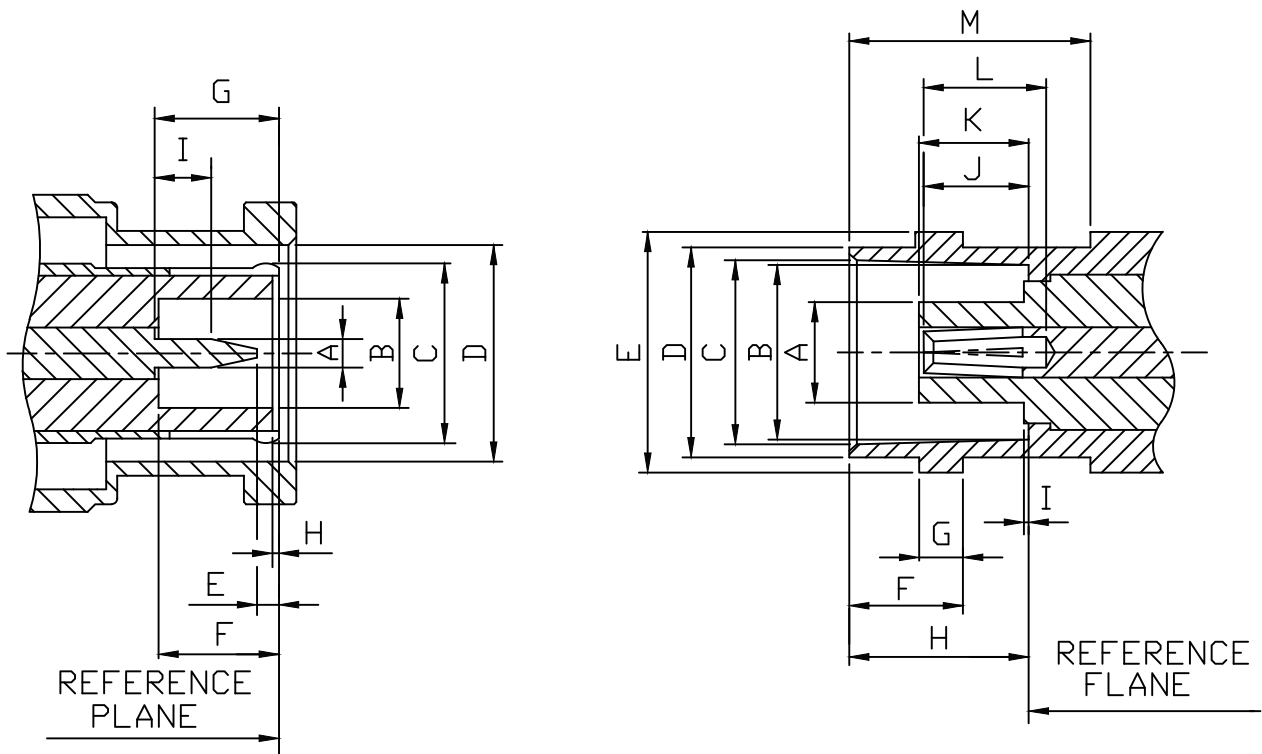

PLUG

Letter	Millimeters (Inches)	
	Minimum	Maximum
A	1.32(.052)	1.37(.054)
B	4.83(.190)	-
C	SLOTTED AND FLARED TO MEET ELECTRICAL AND MECHANICAL REQUIREMENTS	
D	9.78(.385)	9.91(.390)
E	0.08(.003)	-
F	5.28(.208)	5.79(.228)
G	5.33(.210)	5.84(.230)
H	0.15(.006)	-
I	1.98(.078)	-

JACK

Letter	Millimeters (Inches)	
	Minimum	Maximum
A	-	4.72(.186)
B	8.10(.319)	8.15(.321)
C	8.31(.327)	8.46(.333)
D	9.60(.378)	9.68(.381)
E	10.97(.432)	11.07(.436)
F	5.18(.204)	5.28(.208)
G	1.91(.075)	2.06(.081)
H	8.31(.327)	8.51(.335)
I	-	0.15(.006)
J	4.72(.186)	5.23(.206)
K	4.78(.188)	5.28(.208)
L	4.95(.195)	-
M	10.52(.414)	-



BNC Straight Plug Crimp

MODEL 4B12011A06
CABLE RG174U/RG316U

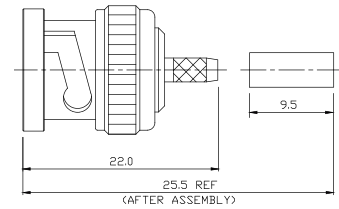
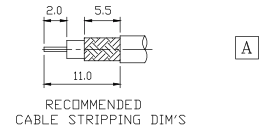

BNC Straight Plug Crimp

MODEL 4B12011A21
CABLE RG58U/RG142U

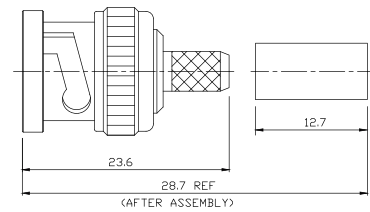
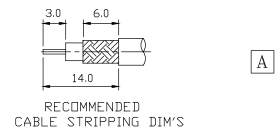

BNC Right Angle Plug Crimp

MODEL 4B12021A06
CABLE RG174U/RG316U

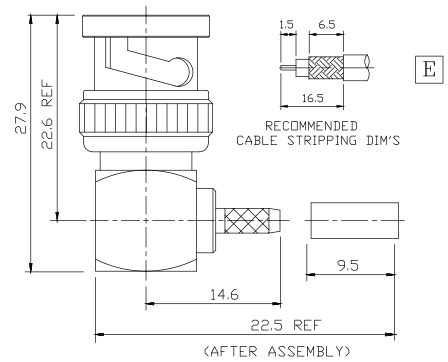

BNC Right Angle Plug Crimp

MODEL 4B12021A21
CABLE RG58U/RG142U

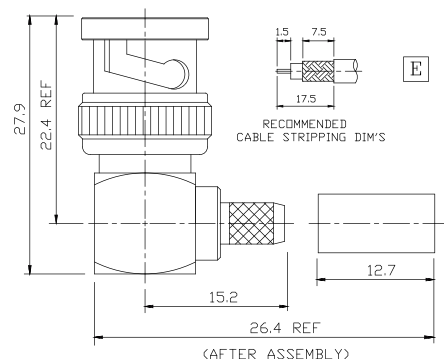



BNC Straight Plug Clamp

MODEL 4B12012A21
CABLE RG58U/RG142U

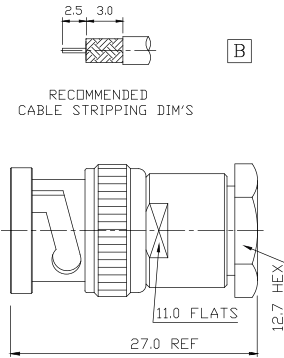

BNC Straight Jack Crimp

MODEL 4B12031A06
CABLE RG174U/RG316U

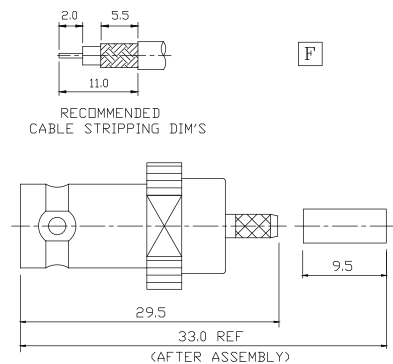

BNC Straight Jack Crimp

MODEL 4B12031A21
CABLE RG58U/RG142U

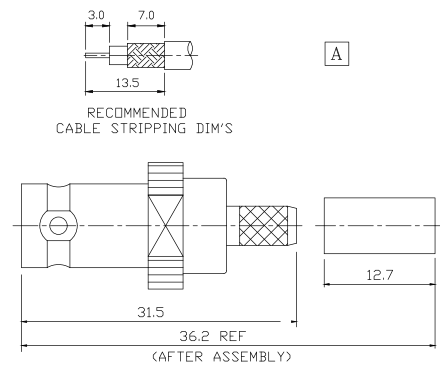

BNC Straight Bulkhead Jack Solder

MODEL 4B12101A01
CABLE ϕ 1.13/ ϕ 1.32
 ϕ 1.37/RG178U

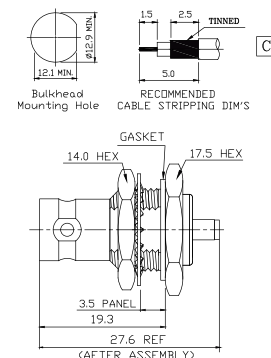



BNC Straight Bulkhead Jack Crimp

MODEL 4B12101A06

CABLE RG174U/RG316U

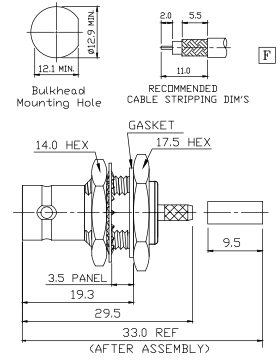

BNC Straight Bulkhead Jack Crimp

MODEL 4B12101A21

CABLE RG58U/RG142U

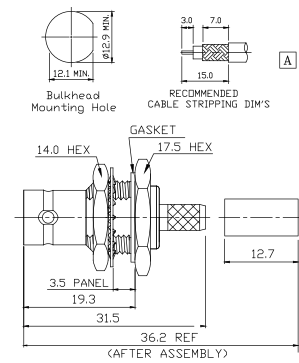

SMA-Series

N-Series

MCX-Series

MMCX-Series

TNC-Series

BNC-Series

SMB-Series

ADAPTE

Light

A

Product Specs Chart

Lightning Arrestor-Series

ANTENNA-Series



MODEL NUMBER PATTERN

□□□□□□□□□□ - □□□□
XXXXXXXXXX-XXX

Electrical

Impedance	50ohm
Frequency Range	0 to 4 GHz
VSWR	1.25+0.04Xf GHz max(Straight) 1.30+0.004Xf GHz max(Right Angle) RG-174,188,316 → 1.25+0.04Xf GHz max(Straight) 1.3+0.04Xf GHz max(Right Angle) RG-178,196 → 1.30+0.004Xf GHz max(Straight) 1.40+0.06Xf GHz max(Right Angle)
Voltage Rating	RG-174,188,316 → 750 volts rms max RG-178,196 → 500 volts rms max
Dielectric Withstanding Voltage	RG-174,188,316 → 750 volts rms max RG-178,196 → 500 volts rms max
Contact Resistance	Center contact = 6.0 Milliohms max Outer contact = 1.0 Milliohms max
RF Leakage	-55dB minimum at 3 GHz
Insertion Loss	0.6 dB max at 3 GHz
Insulation Resistanec	1000 Megaohms min

Mechanical & Environmental

Mating	Snap-on coupling
Durability	500 matings min
Coupling Nut Retention	40 lbs min
Cable Retention	RG-178,196 → 6 lbs min RG-174,188,316 → 20 lbs min
Temperature Range	-65 °C to 165 °C
Vibration	MIL-STD-202 Method 204 Test Cond.B.
Salt Spray	MIL-STD-202 Method 201 Test Cond.B.
Temperature Cycling	MIL-STD-202 Method 107 Test Cond.B.

Material

	Material	Plating
Connector Body	Brass	Gold or Nickel
Center Contact	Male:Brass Female:Beryllium Copper	Gold Gold
Insulation	Teflon	None
Gasket	Silicone	None
Crimp Ferrule	Annealed Copper	Same as Body

Interface Mating Dimensions

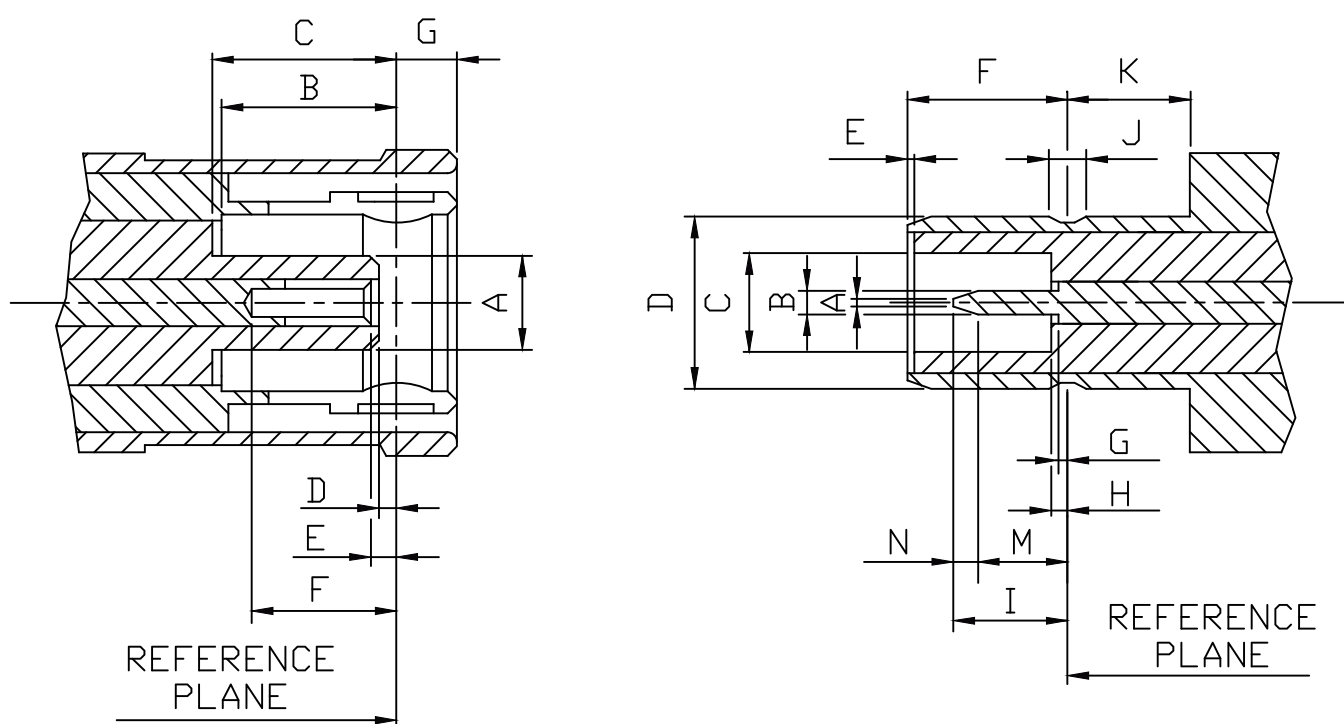

PLUG

Letter	Millimeters (Inches)	
	Minimum	Maximum
A	-	2.06 (.081)
B	3.58 (.141)	-
C	3.58 (.141)	-
D	0.18 (.007)	-
E	0.18 (.007)	0.94 (.037)
F	2.97 (.117)	-
G	-	1.63 (.064)

JACK

Letter	Millimeters (Inches)	
	Minimum	Maximum
A	-	0.25 (.010)
B	0.48 (.019)	0.53 (.021)
C	2.08 (.082)	-
D	3.66 (.144)	3.71 (.146)
E	0.00 (.000)	-
F	3.33 (.131)	3.58 (.141)
G	-	0.18 (.007)
H	-	0.18 (.007)
I	2.39 (.094)	2.97 (.117)
J	0.69 (.027)	0.94 (.037)
K	1.65 (.065)	-
M	1.31(.052)	-
N	0.25(.010)	-



SMB Straight Plug Crimp

MODEL 4B24011B21
CABLE RG58U/RG142U

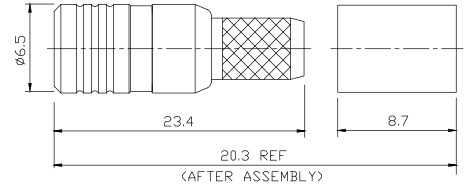
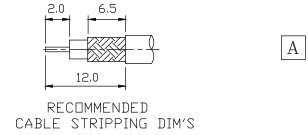

SMB Straight Plug Crimp

MODEL 4B24011B06
CABLE RG174U/RG316U

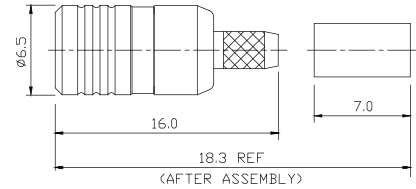
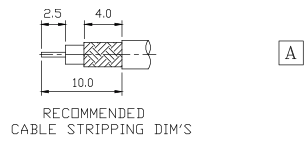

SMB Straight Bulkhead Jack Crimp

MODEL 4B24071B03
CABLE $\phi 1.13/\phi 1.32$
 $\phi 1.37$ /RG178U

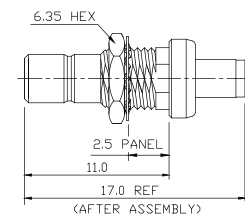
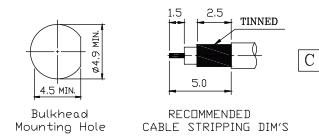

SMB Straight Bulkhead Jack Crimp

MODEL 4B24071B06
CABLE RG174U/RG316U

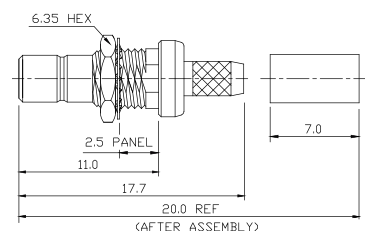
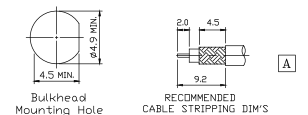

SMB Straight Jack Crimp



MODEL 4B24031B21
CABLE RG58U/RG142U

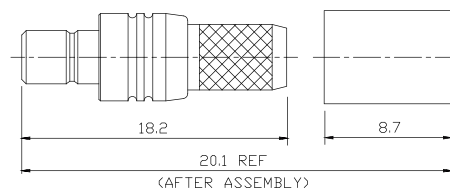
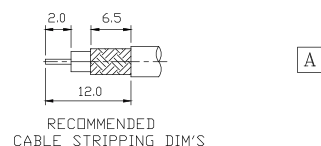

SMB Straight Jack Crimp



MODEL 4B24031B06
CABLE RG174U/RG316U

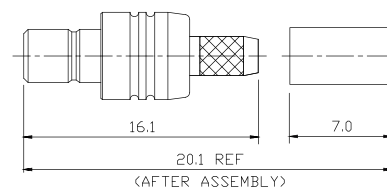
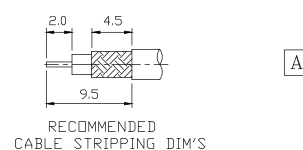

SMB Right Angle Plug Crimp



MODEL 4B24021B21
CABLE RG58U/RG142U

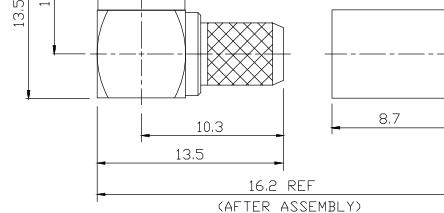
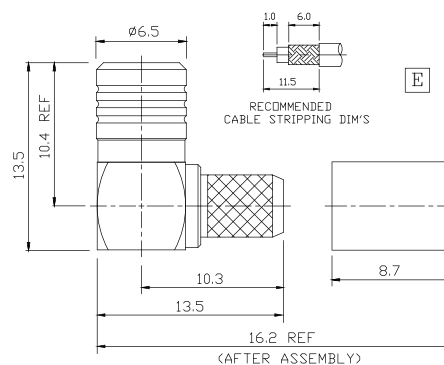

SMB Right Angle Plug Crimp



MODEL 4B24021B06
CABLE RG174U/RG316U

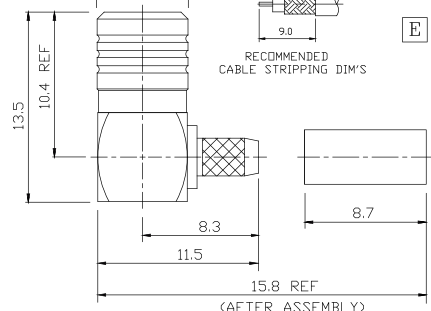
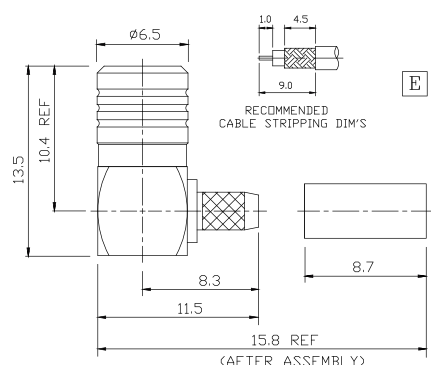



**SMB Right Angle Jack
PCB Mount**

MODEL 4B2404PBPM
CABLE PCB Mount

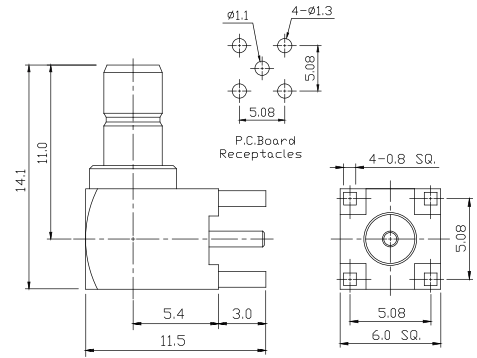

**SMB Straight Jack
PCB Mount**

MODEL 4B2403PBPM
CABLE PCB Mount

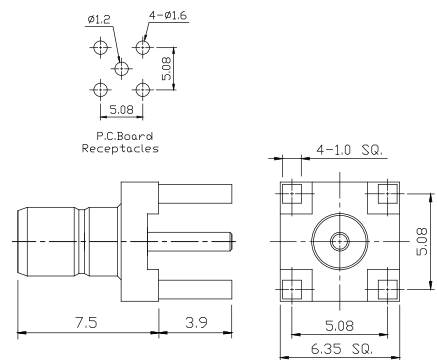

**SMB Right Angle Plug
PCB Mount**

MODEL 4B2402PBPM
CABLE PCB Mount

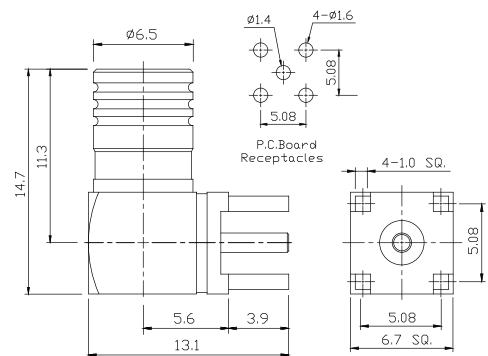

SMB Right Angle Jack Crimp

MODEL 4B24041B06
CABLE RG174U/RG316U

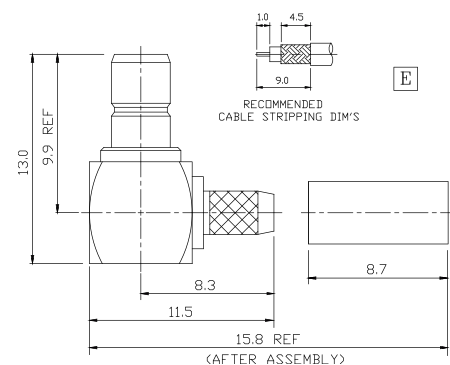



SMB Straight Bulkhead Jack Receptacle

MODEL 4B2405PBRP

CABLE Receptacle

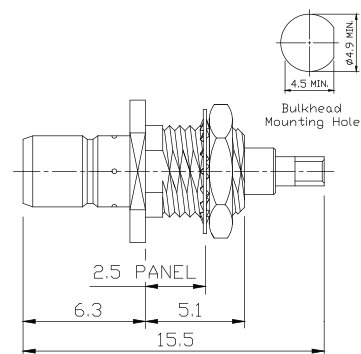

SMB Straight Jack Recessed Receptacle Rear Nut Fixing

MODEL 4B2403PBRE

CABLE Receptacle

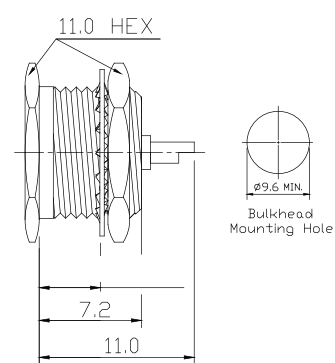

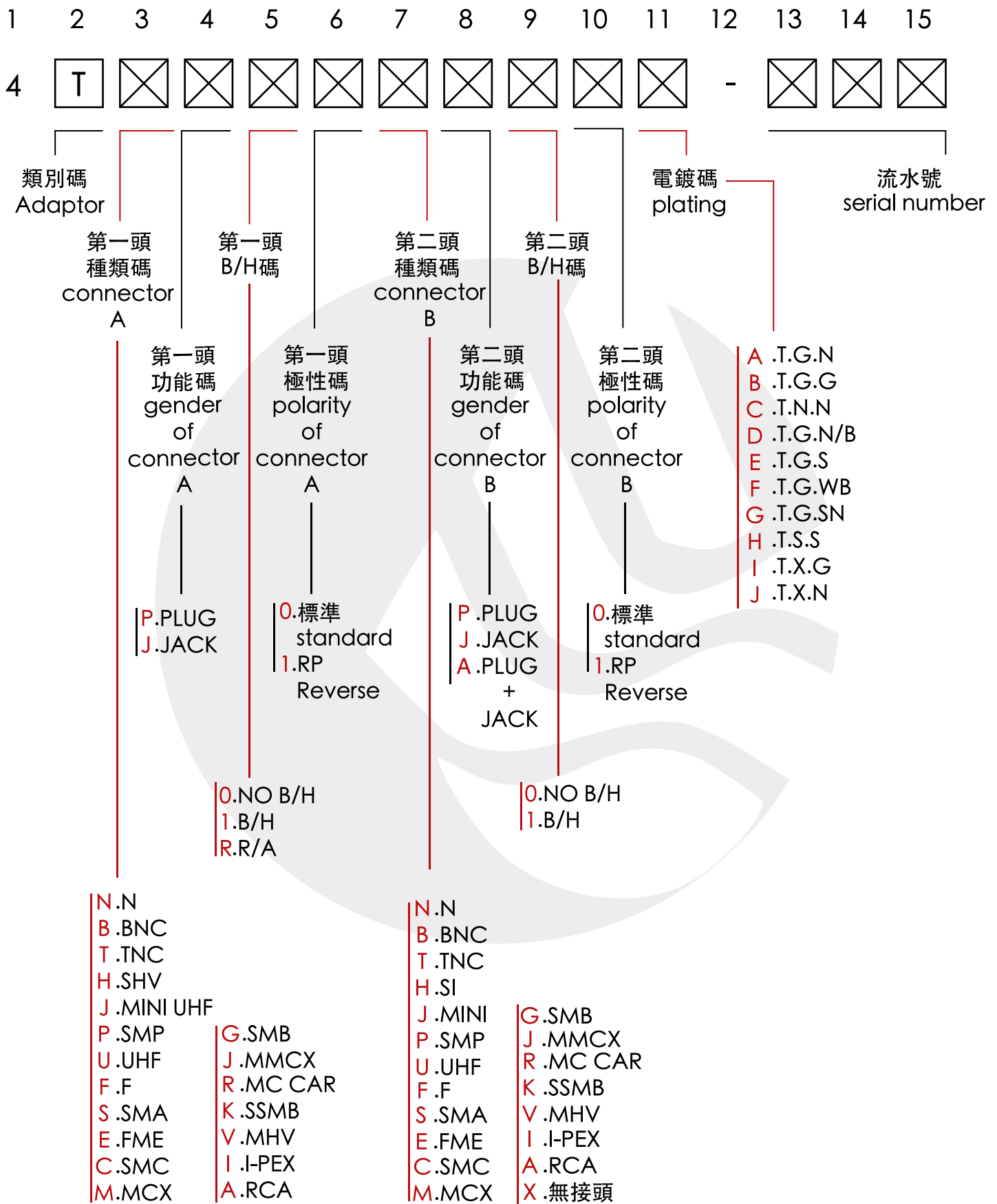

SMA-Series

N-Series

MCX-Series

MMCX-Series

TNC-Series

BNC-Series

SMB-Series

Product Specs Chart

ADAPT

Light

A

Lightning Arrestor-Series

ANTENNA-Series



MODEL NUMBER PATTERN

□□□□□□□□□□ - □□□□
XXXXXXXXXX-XXX



N Plug to Plug

MODEL 4TNP00NP00A

CABLE N/A

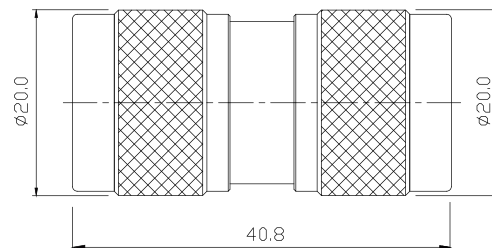

N Plug to Jack

MODEL 4TNP00NJ00A

CABLE N/A

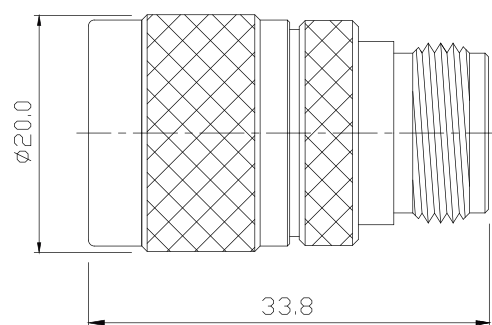

N Jack to Jack

MODEL 4TNJ00NJ00A

CABLE N/A

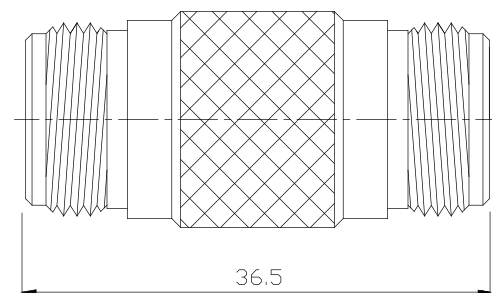

N Plug to BNC Jack

MODEL 4TNP00BJ00A

CABLE N/A

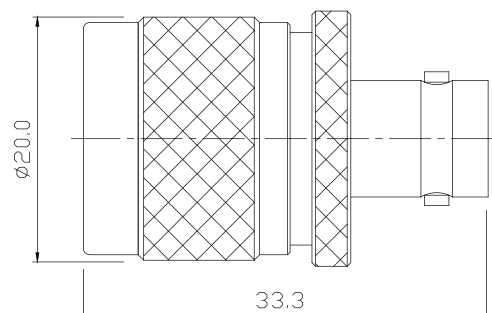



N Plug to TNC Jack

MODEL 4TNP00TJ00A
CABLE N/A

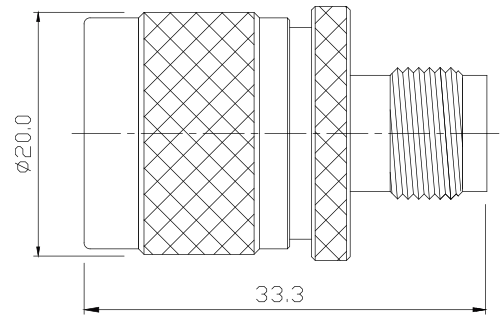

N Plug to N Plug Right Angle

MODEL 4TNPR0NP00A
CABLE N/A

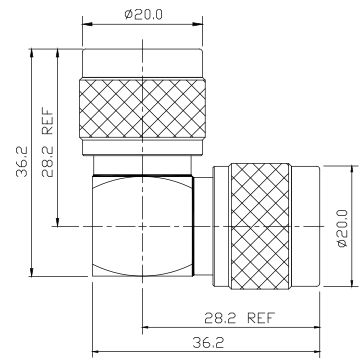

SMA Jack to SMA Jack

MODEL 4TSJ00SJ00B
CABLE N/A

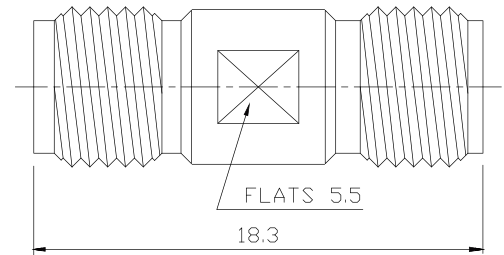

SMA Jack Bulkhead to SMA Jack

MODEL 4TSJ10SJ00B
CABLE N/A

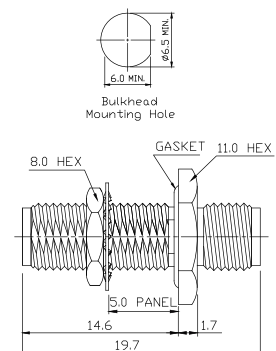



SMA Plug to SMA Plug

MODEL 4TSP00SP00B

CABLE N/A

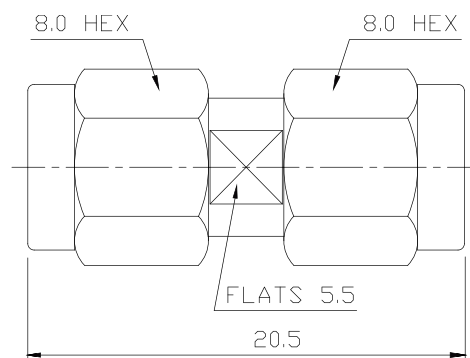

SMA Plug to BNC Jack

MODEL 4TSP00BJ00A

CABLE N/A

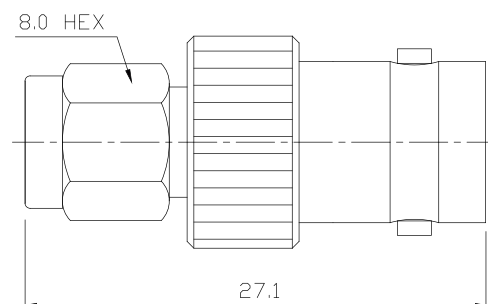

SMA Plug to N Plug

MODEL 4TSP00NP00A

CABLE N/A

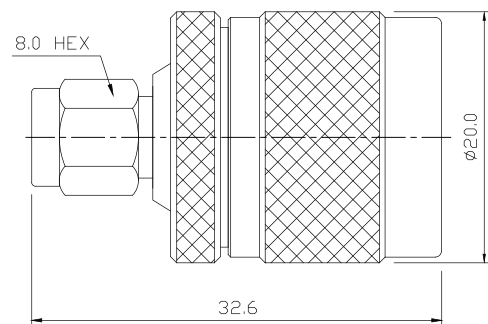

SMA Plug to N Jack

MODEL 4TSP00NJ00A

CABLE N/A

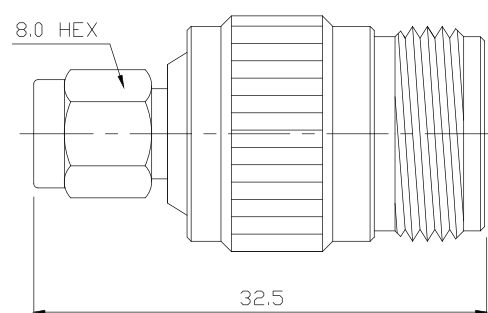



SMA Plug to TNC Jack

MODEL 4TSP00TJ00A
CABLE N/A

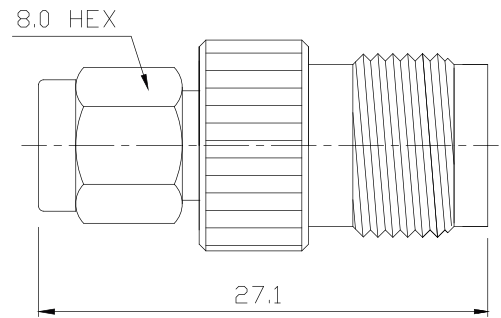

SMA Jack to BNC Plug

MODEL 4TSJ00BP00A
CABLE N/A

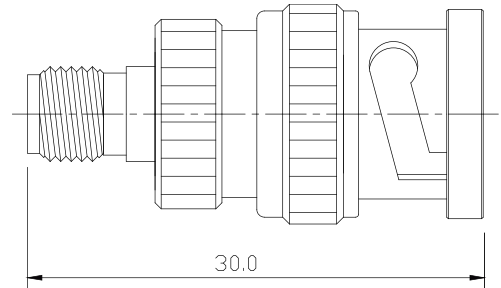

SMA Jack to TNC Plug

MODEL 4TSJ00TP00A
CABLE N/A

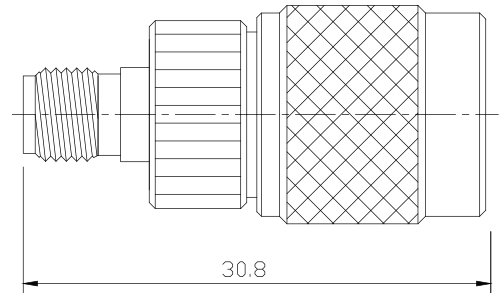

SMA Jack to N Plug

MODEL 4TSJ00NP00A
CABLE N/A

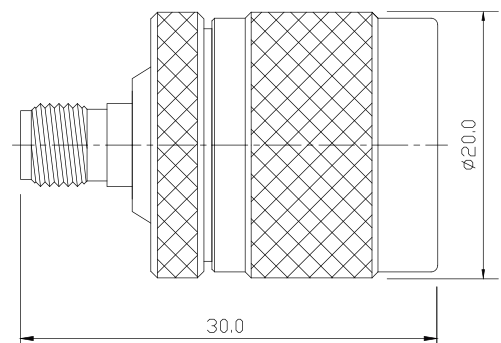



SMA Jack to N Jack

MODEL 4TSJ00NJ00A

CABLE N/A

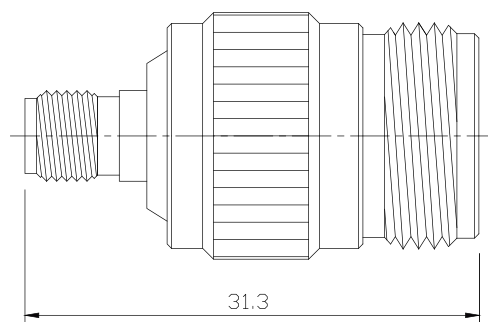

SMA Plug Right Angle to SMA Jack

MODEL 4TSPR0SJ00B

CABLE N/A

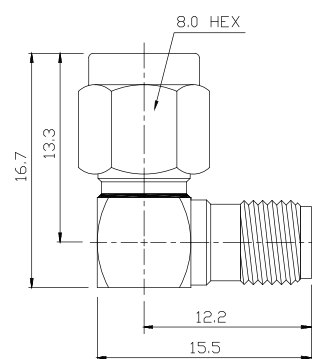

SMA Jack to MCX Plug

MODEL 4TSJ00MP00B

CABLE N/A

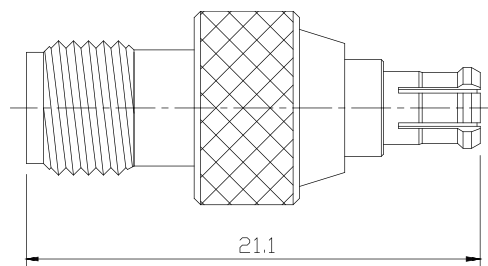

SMA Jack to MCX Jack

MODEL 4TSJ00MJ00B

CABLE N/A

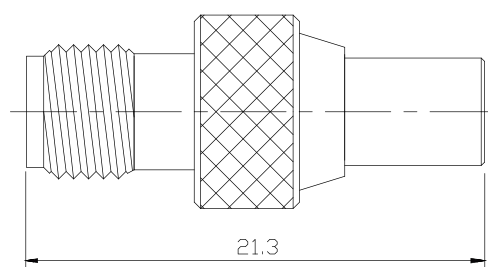



SMA Plug to MCX Plug

MODEL 4TSP00MP00B
CABLE N/A

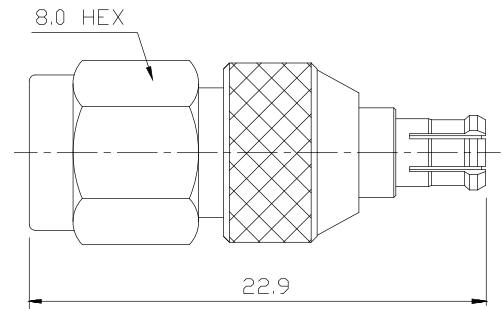

SMA Plug to MCX Jack

MODEL 4TSP00MJ00B
CABLE N/A

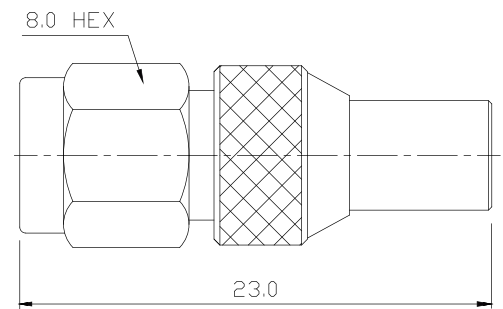

SMA Jack to SMB Jack

MODEL 4TSJ00GJ00B
CABLE N/A

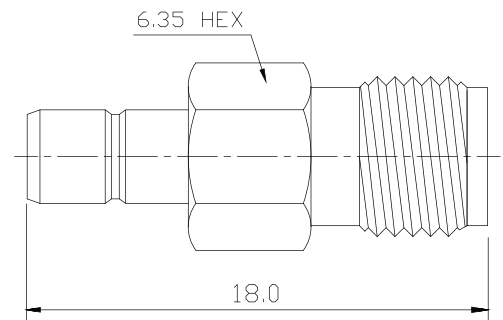

SMA Jack to MMCX Plug

MODEL 4TSJ00LP00B
CABLE N/A

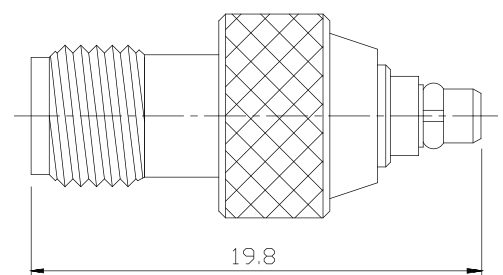



SMA Plug to IPEX Jack

MODEL 4TSP00IJ00A

CABLE N/A

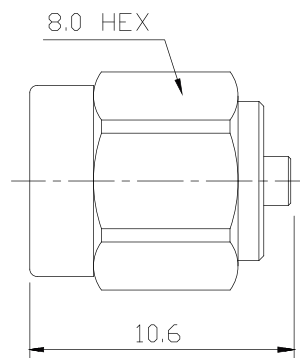

SMA Jack to MMCX Jack

MODEL 4TSJ00LJ00B

CABLE N/A

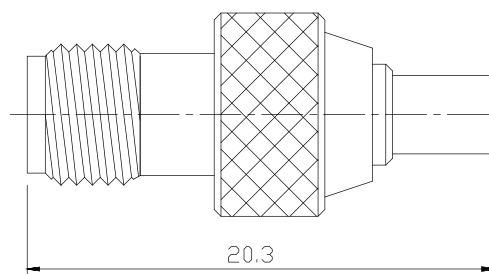

BNC Jack to BNC Jack Bulkhead

MODEL 4TBJ10BJ00A

CABLE N/A

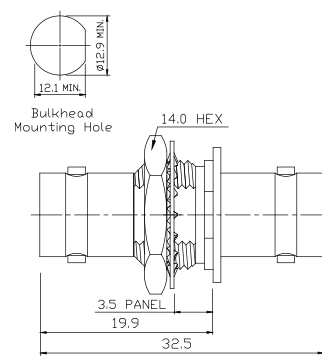

BNC Jack to N Jack

MODEL 4TBJ00NJ00A

CABLE N/A

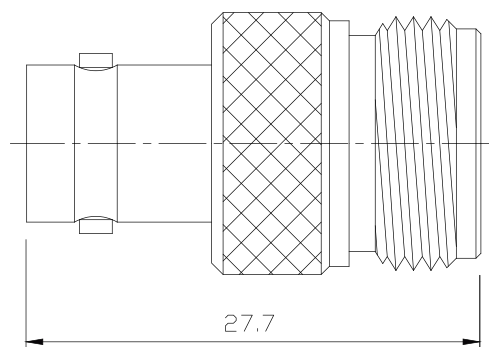



BNC Tee Adapter Jack to Plug to Jack

MODEL 4TBP00BJ00A

CABLE N/A

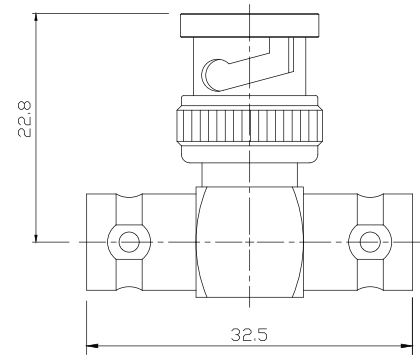

TNC Jack to BNC Plug

MODEL 4TTJ00BP00A

CABLE N/A

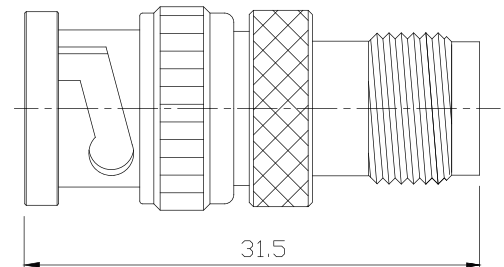

UHF Jack to UHF Jack

MODEL 4TUJ00UJ00A

CABLE N/A

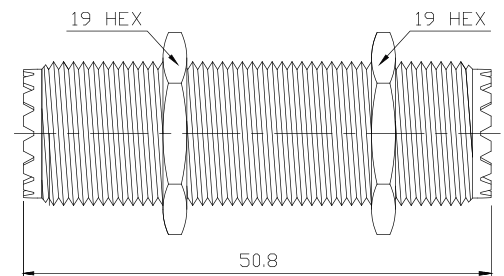

F Jack to F Jack

MODEL 4TFJ00FJ00A

CABLE N/A

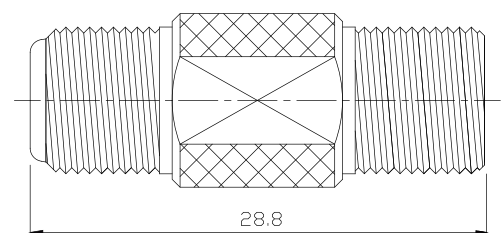



FME Plug to FME Plug

MODEL 4TEP00EP00A

CABLE N/A

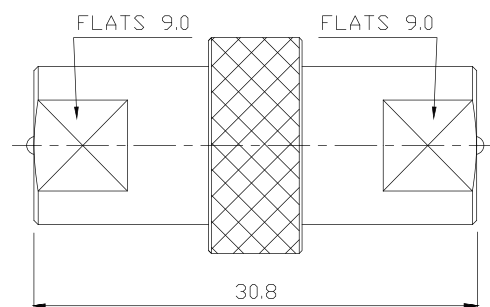

MCX Plug to MCX Jack

MODEL 4TMP00MJ00B

CABLE N/A

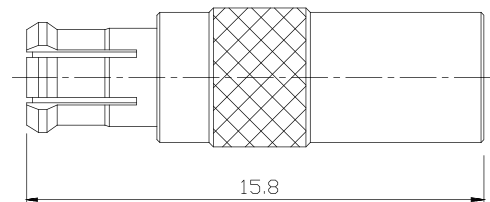

N Plug to TNC Plug Reverse Polarity

MODEL 4TNP01TP00A

CABLE N/A

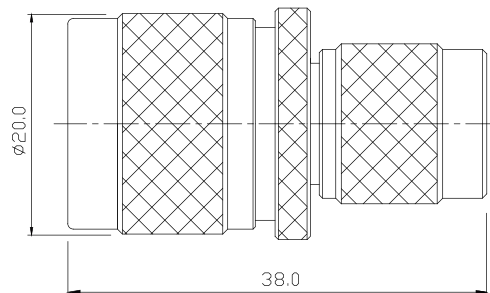

N Plug to TNC Jack Reverse Polarity

MODEL 4TNP00TJ01A

CABLE N/A

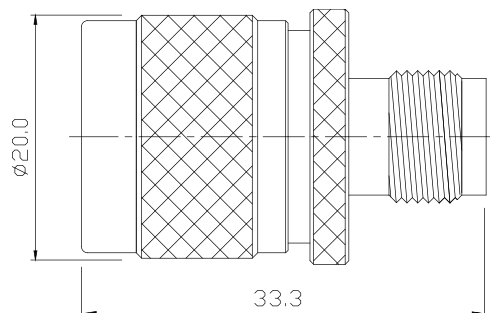



**SMA Jack to SMA Jack
Reverse Polarity**

MODEL 4TSJ00SJ01B
CABLE N/A

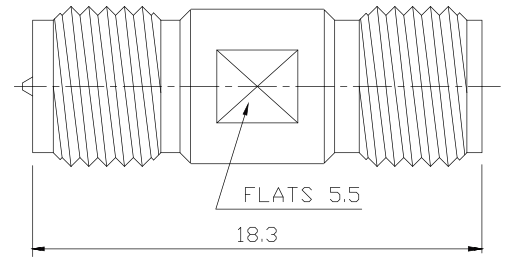

**SMA Plug Reverse Polarity to
SMA Plug Reverse Polarity**

MODEL 4TSP01SP01B
CABLE N/A

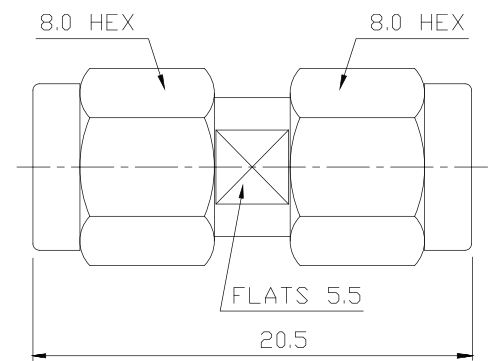

**SMA Plug Reverse Polarity to
N Jack**

MODEL 4TSP01NJ00A
CABLE N/A

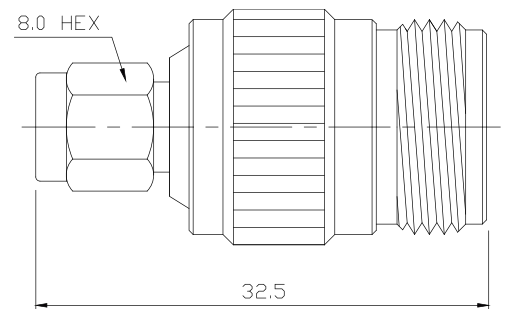

**SMA Plug to TNC Plug
Reverse Polarity**

MODEL 4TSP00TP01A
CABLE N/A

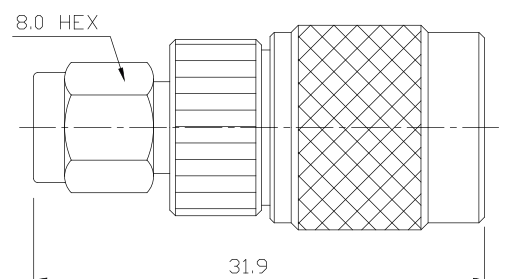



**SMA Jack to TNC Plug
Reverse Polarity**

MODEL 4TSJ00TP01A
CABLE N/A

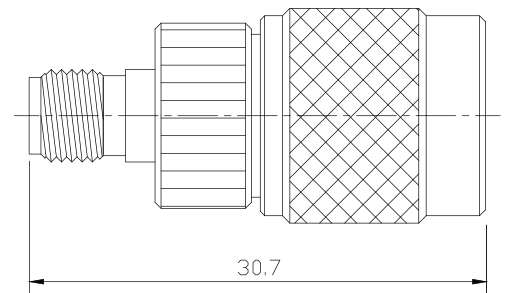

**SMA Jack Reverse Polarity
to N Plug**

MODEL 4TSJ01NP00A
CABLE N/A

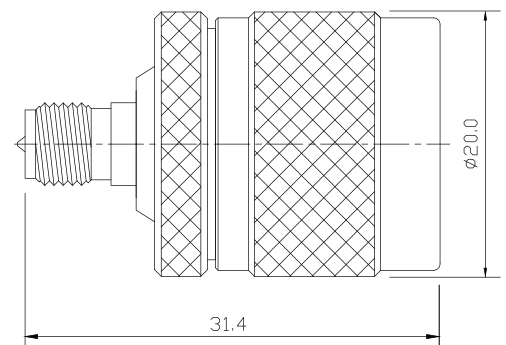

**SMA Jack Reverse Polarity
to N Jack**

MODEL 4TSJ01NJ00A
CABLE N/A

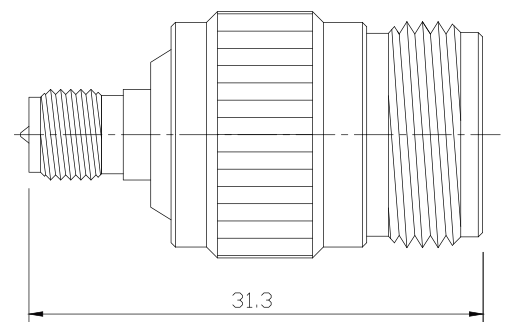

**SMA Plug Right Angle Reverse
Polarity to SMA Jack Reverse
Polarity**

MODEL 4TSPR1SJ01B
CABLE N/A

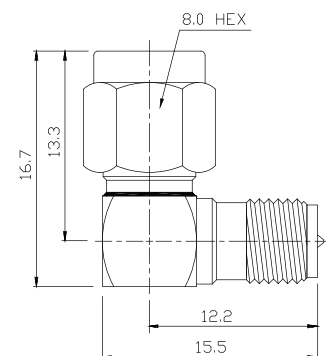



TNC Plug Reverse Polarity to
FME Plug

MODEL 4TTP01EP00A

CABLE N/A

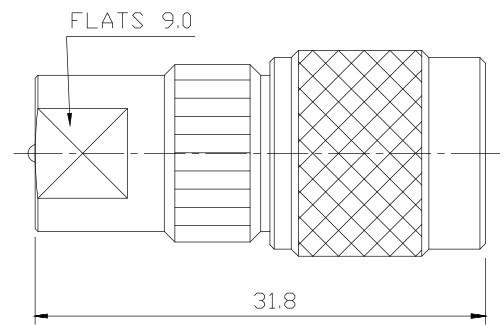

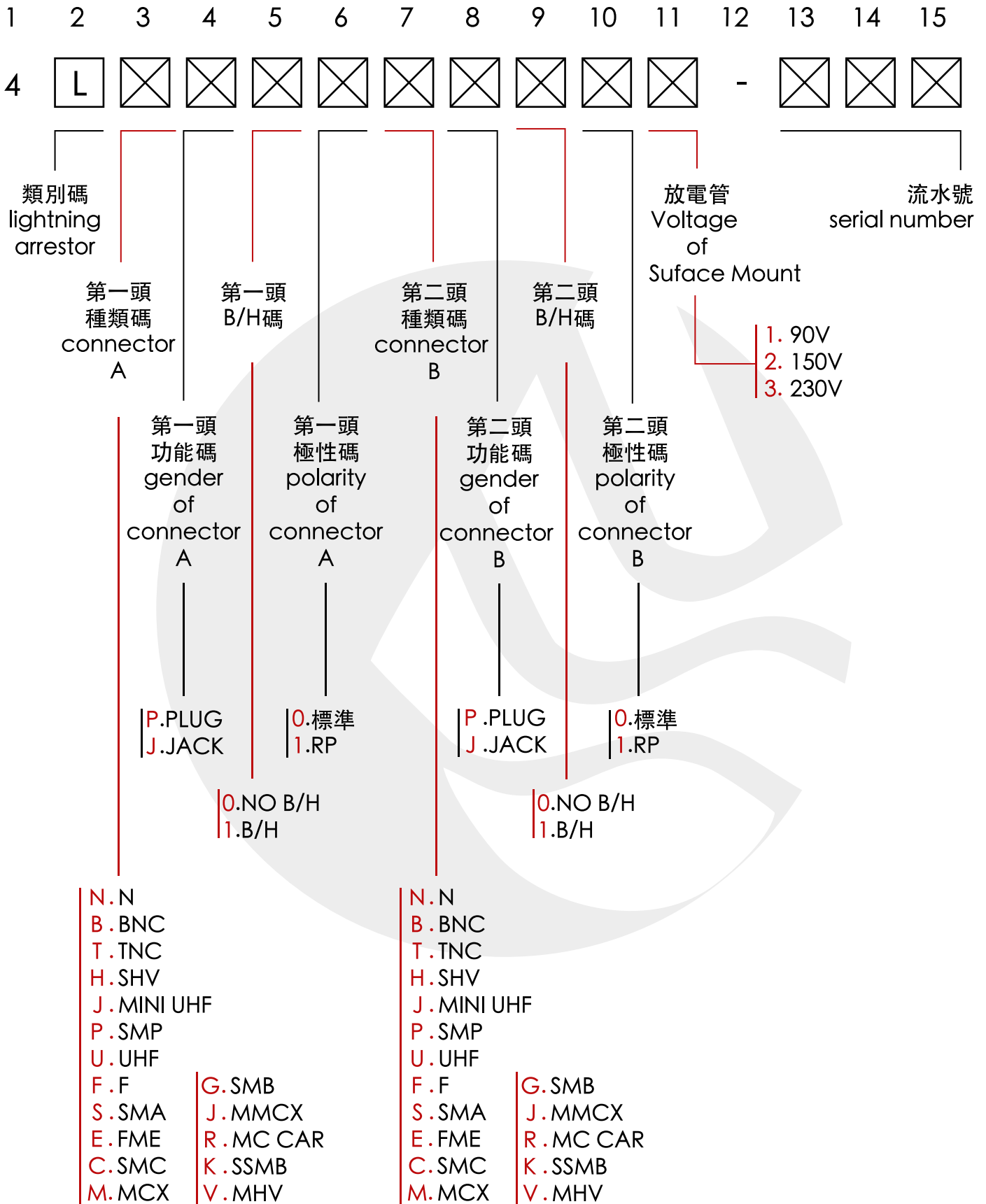

SMA-Series

N-Series

MCX-Series

MMCX-Series

TNC-Series

BNC-Series

SMB-Series

ADAPT

Product Specs Chart

Lig
A

LightningArrestor-Series



MODEL NUMBER PATTERN
□□□□□□□□□□ - □□□□
XXXXXXXXXXXX-XXX

SOCAA's lightning arrestor is gas discharge tube suppressor features high frequency range up to 6 GHz and is rated IP67

Frequency Range	DC 0~6 GHz
Insertion Loss	0.7dB
VSWR	1.5 max
Impedance	50
Gas Tube DC Spark Over Voltage	90 or 230V
Operating Temperature Range	-40 F to 165 F
Insulation Resistance	2000M
D.C Discharge Voltage	184-276V (100V/S)
Initial Impulse Wave Discharge Voltage	450-500V(1KV/ μ s)
Rated Impulse Wave Discharge	10KA(wave 8/20 μ s) 10 times (5 time Each Polarity)



Reverse Polarity TNC Jack to Reverse Polarity TNC Plug

MODEL 4LTJ11TP011

Voltage 90V

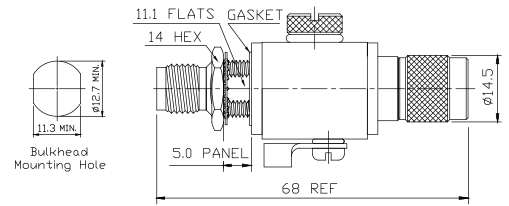

SMA Jack to SMA Jack Bulkhead

MODEL 4LSJ10SJ003

Voltage 230V

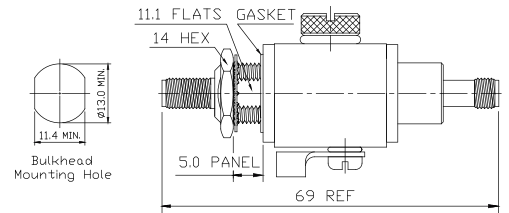

Reverse Polarity SMA Jack Bulkhead to Reverse Polarity SMA Plug

MODEL 4LSJ11SP013

Voltage 230V

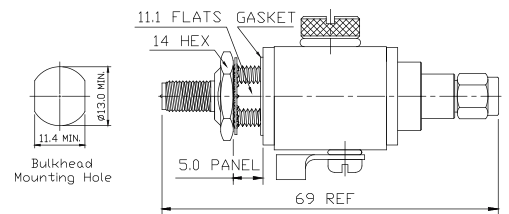

Reverse Polarity N Jack Bulkhead to Reverse Polarity N Jack

MODEL 4LNJ11NJ013

Voltage 230V

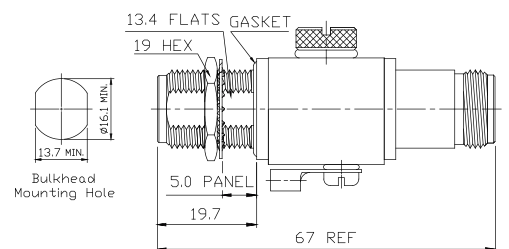



N Jack Bulkhead to N Jack

MODEL 4LNJ10NJ003

Voltage 230V

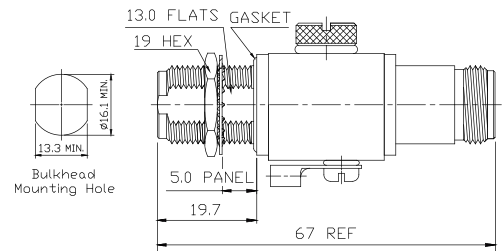

N Jack Bulkhead to N Jack

MODEL 4LNJ10NJ001

Voltage 90V

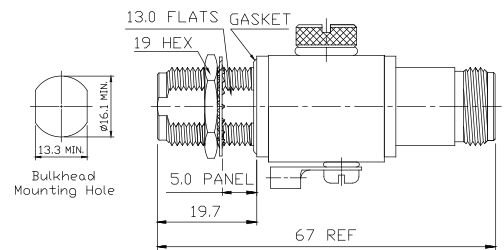

SMA Jack Bulkhead to SMA Jack

MODEL 4LSJ10SJ001

Voltage 90V

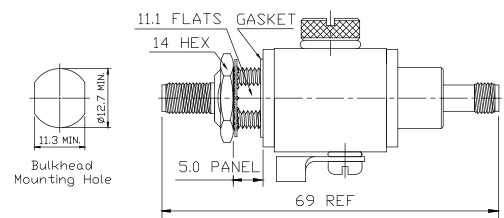

N Jack Bulkhead to N Plug

MODEL 4LNJ10NP001

Voltage 90V

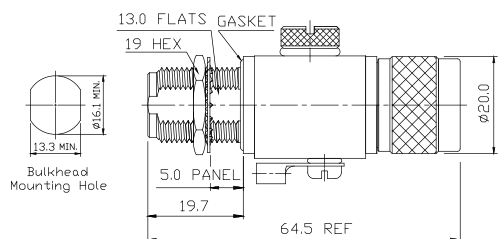



TNC Jack Bulkhead to TNC Plug

MODEL 4LTJ10TP001

Voltage 90V

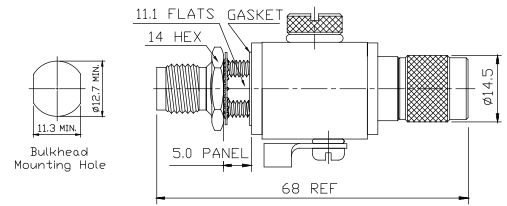

Reverse Polarity SMA Jack Bulkhead to Reverse Polarity SMA Plug

MODEL 4LSJ11SP011

Voltage 90V

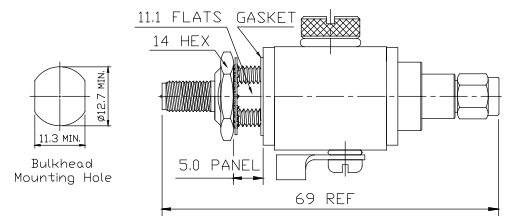

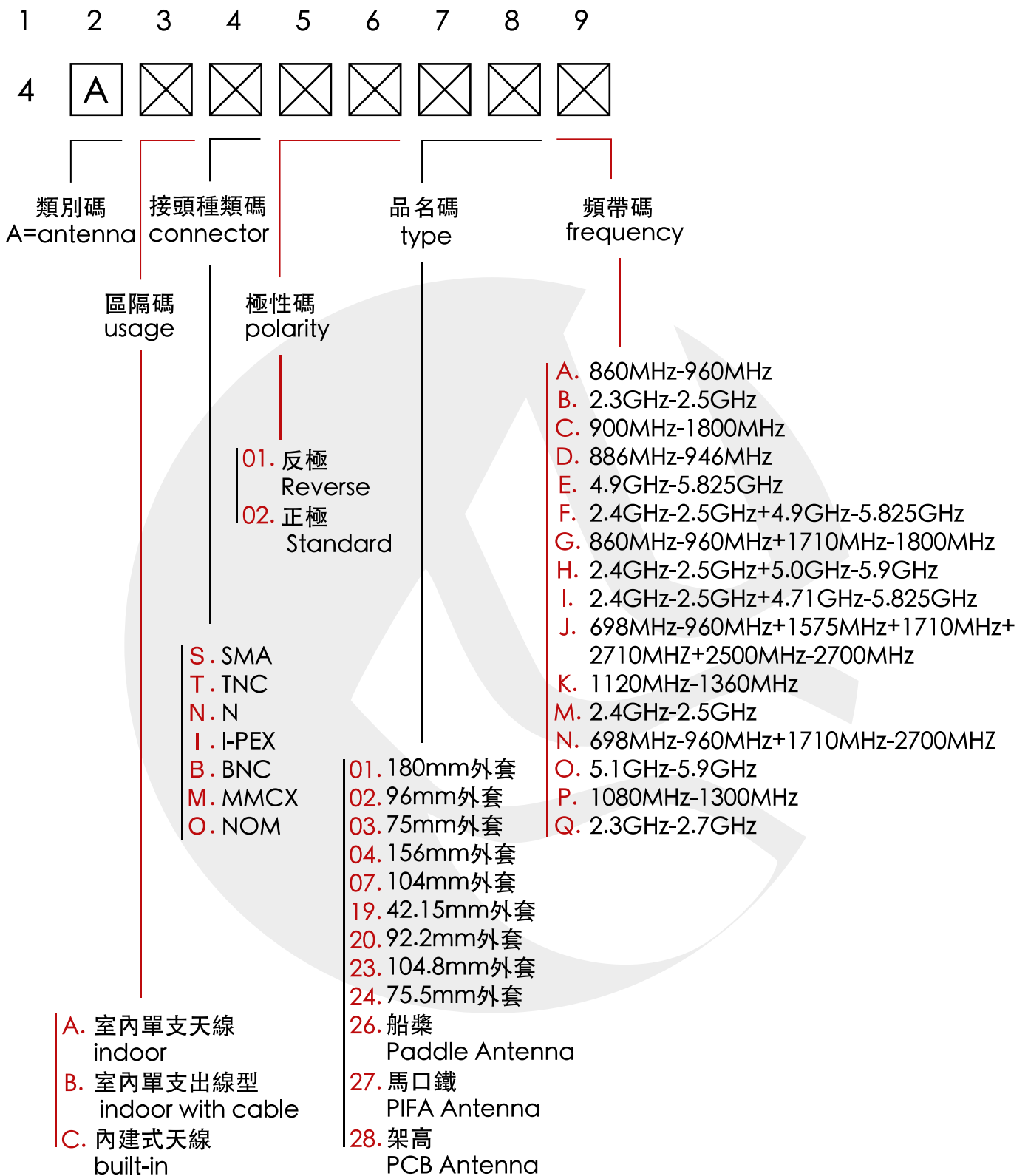

SMA-Series

N-Series

MCX-Series

MMCX-Series

TNC-Series

BNC-Series

SMB-Series

ADAPT

Light



Product Specs Chart

Lightning Arrestor-Series

ANTENNA-Series



MODEL NUMBER PATTERN

□□□□□□□□□□ - □□□□
XXXXXXXXXX-XXX



MODEL 4AAB0102M
Frequency 2.4~2.5GHz
Gain 2.0dBi
SWR 2.0Max
Impedance 50Ω
Connector BNC Plug
 Reverse Polarity

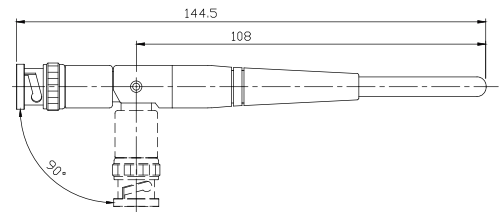

MODEL 4AAS0103M
Frequency 2.4~2.5GHz
Gain 2.0dBi
SWR 2.0Max
Impedance 50Ω
Connector SMA Plug
 Reverse Polarity

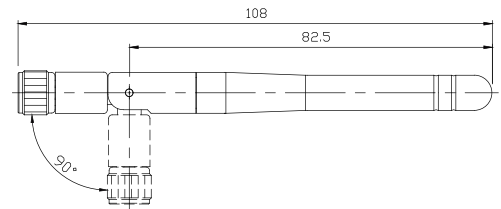

MODEL 4AAS0203M
Frequency 2.4~2.5GHz
Gain 2.0dBi
SWR 2.0Max
Impedance 50Ω
Connector SMA Plug

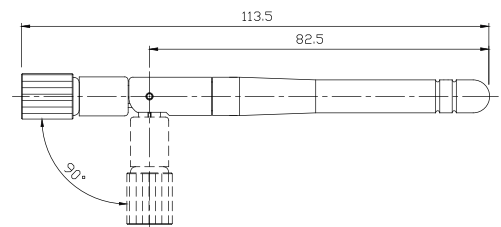

MODEL 4AAS0219M
Frequency 2.4~2.5GHz
Gain 2.0dBi
SWR 2.0Max
Impedance 50Ω
Connector SMA Plug

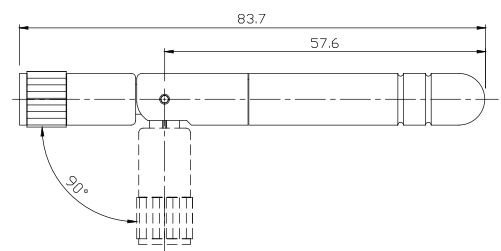



MODEL 4AAN0204F
Frequency 2.4~2.5GHz
 4.9~5.825GHz
Gain 2.0dBi
SWR 2.0Max
Impedance 50Ω
Connector N Plug

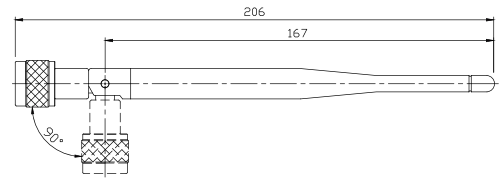

MODEL 4AAS0102F
Frequency 2.4~2.5GHz
 4.9~5.825GHz
Gain 2.0dBi
SWR 2.0Max
Impedance 50Ω
Connector SMA Plug
 Reverse Polarity

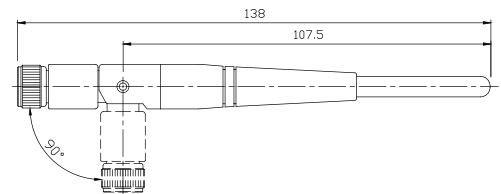

MODEL 4AAS0104F
Frequency 2.4~2.5GHz
 4.9~5.825GHz
Gain 2.5dBi
SWR 2.0Max
Impedance 50Ω
Connector SMA Plug
 Reverse Polarity

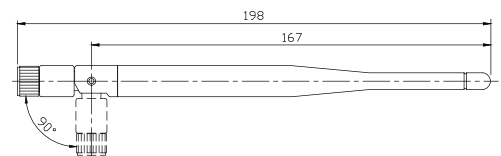

MODEL 4AAS0107F
Frequency 2.4~2.5GHz
 4.9~5.825GHz
Gain 2.0dBi / 4.5dBi
SWR 2.0Max
Impedance 50Ω
Connector SMA Plug
 Reverse Polarity

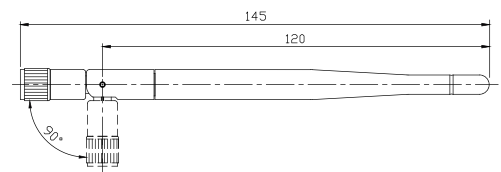



MODEL 4AAS0123F
Frequency 2.4~2.5GHz
 4.9~5.825GHz
Gain 2.0dBi / 3.0dBi
SWR 2.0Max
Impedance 50Ω
Connector BNC Plug
 Reverse Polarity

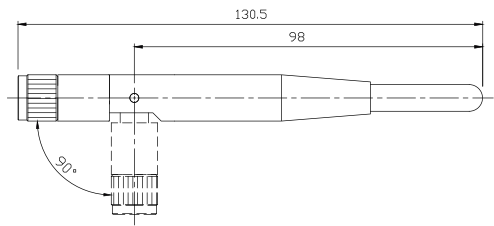

MODEL 4AAS0124F
Frequency 2.4~2.5GHz
 4.9~5.825GHz
Gain 2.0dBi
SWR 2.0Max
Impedance 50Ω
Connector SMA Plug
 Reverse Polarity

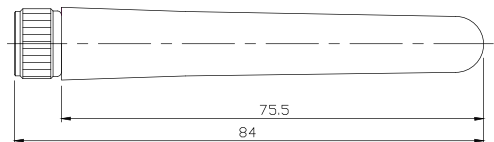

MODEL 4AAS0202F
Frequency 2.4~2.5GHz
 4.9~5.825GHz
Gain 2.0dBi
SWR 2.0Max
Impedance 50Ω
Connector SMA Plug

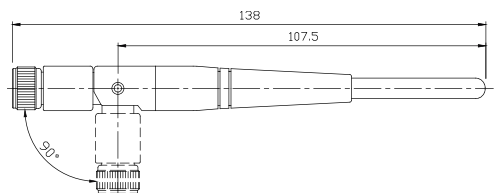

MODEL 4AAT0104F
Frequency 2.4~2.5GHz
 4.9~5.825GHz
Gain 2.0dBi
SWR 2.0Max
Impedance 50Ω
Connector TNC Plug
 Reverse Polarity

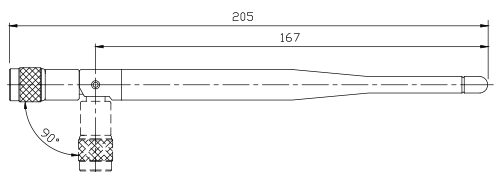



MODEL 4AAT0124F
Frequency 2.4~2.5GHz
 4.9~5.825GHz
Gain 2.0dBi
SWR 3.0Max
Impedance 50Ω
Connector TNC Plug
 Reverse Polarity

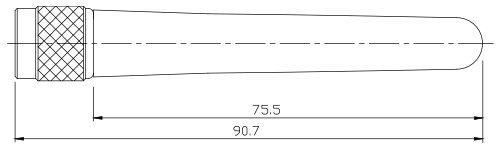

MODEL 4AAT0223F
Frequency 2.4~2.5GHz
 4.9~5.825GHz
Gain 2.0dBi
SWR 2.0Max
Impedance 50Ω
Connector TNC Plug

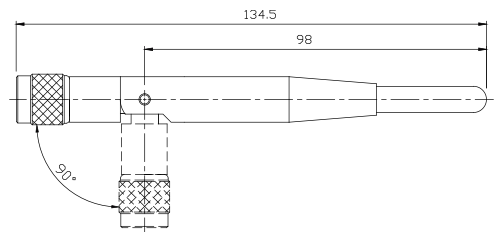

MODEL 4AAS0101D
Frequency 860~960GHz
Gain 2.0dBi
SWR 2.0Max
Impedance 50Ω
Connector SMA Plug
 Reverse Polarity

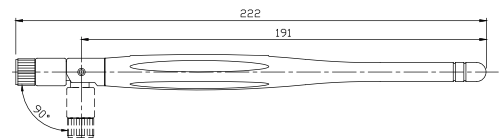

MODEL 4AAN0201D
Frequency 886~946GHz
Gain 2.0dBi
SWR 2.0Max
Impedance 50Ω
Connector N Plug

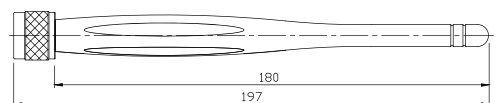



MODEL 4AAT0201G
Frequency 880~960GHz
1710~1880GHz
Gain 2.0dBi
SWR 2.5Max
Impedance 50Ω
Connector TNC Plug

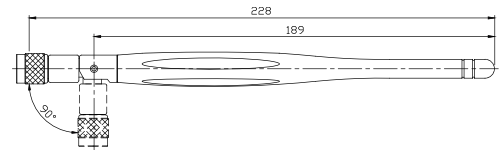

MODEL 4AAS0126L
Frequency 698~960GHz
1710~2170GHz
2500~2700GHz
Gain 1.0~3.5dBi
SWR 2.5Max
Impedance 50Ω
Connector SMA Plug Reverse

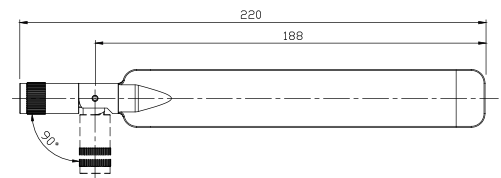



Assembly Flowchart

組裝流程

Cable Assembly Instruction A

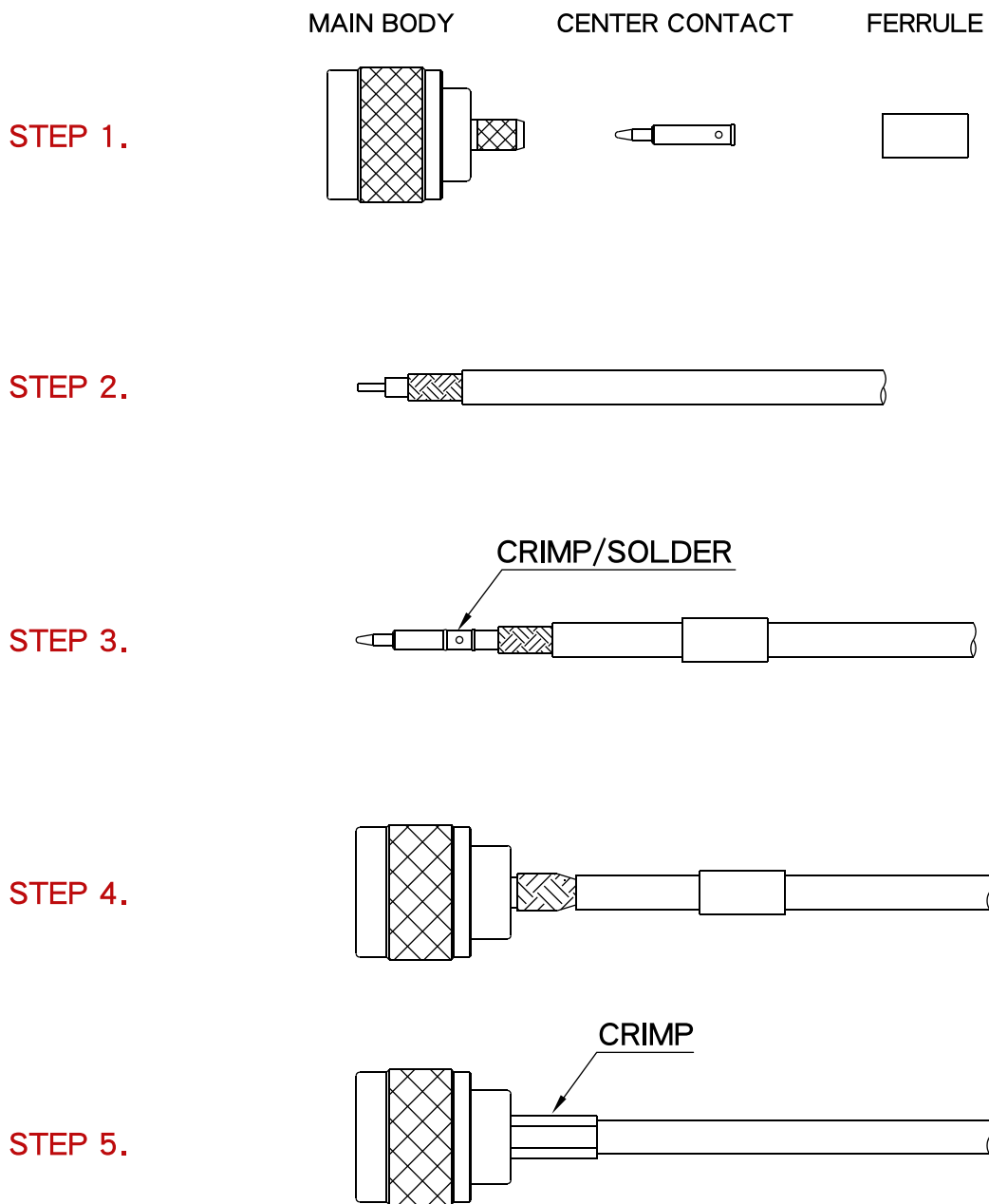

STEP 1. All parts of the connector are shown. A crimp tool is necessary to complete the termination

STEP 2. Strip the cable inner conductor, dielectric, braid, and jacket as per "RECOMMENDED CABLE STRIPPING DIM' S in catalog

STEP 3. Insert inner conductor into the CENTER CONTACT and crimp it with the crimp tool as shown. Then slide the FERRULE onto cable

STEP 4. Insert the MAIN BODY into braid and dielectric

STEP 5. Slide the FERRULE over braid and crimp it with the crimp tool as shown

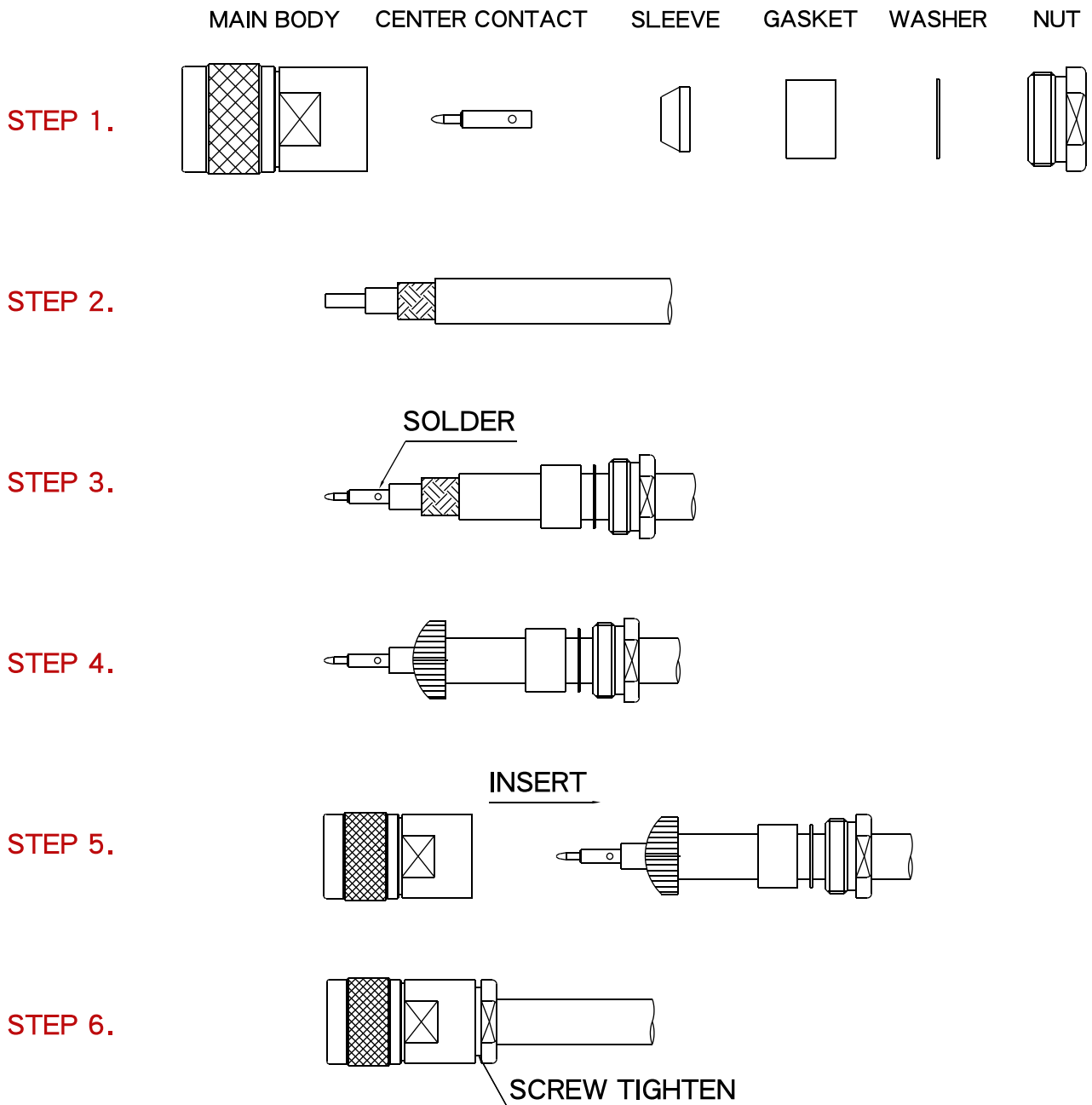

STEP 1. All parts of the connectors are shown

STEP 2. Strip the cable inner conductor, dielectric, braid, and jacket as per "RECOMMENDED CABLE STRIPPING DIM'S" in catalog

STEP 3. Insert inner conductor into the CENTER CONTACT and solder it as shown. Then slide the NUT, WASHER, and GASKET onto cable one by one

STEP 4. Place the SLEEVE over braid and push back against cable jacket. Fold back braid wire as shown.

STEP 5. Insert cable and parts into the MAIN BODY, then screw the NUT until it is tightened

Cable Assembly Instruction C

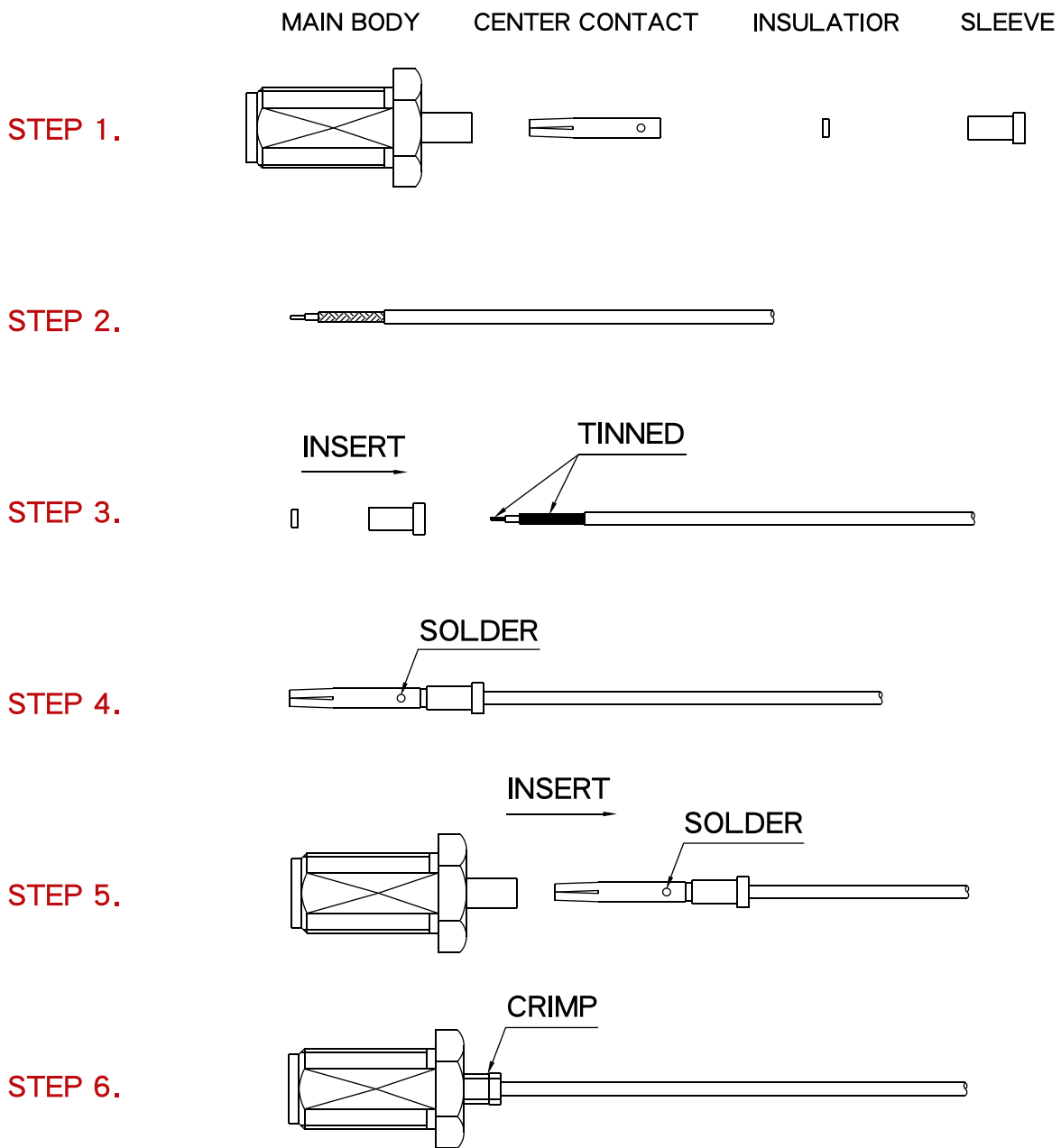

STEP 1. All parts of the connectors are shown.

STEP 2. Strip the cable inner conductor, braid, and jacket as per "RECOMMENDED CABLE STRIPPING DIM'S in catalog

STEP 3. Insert the INSULATOR and SLEEVE into the cable and solder it as shown.

STEP 4. Insert cable and parts into the Center Contact and solder it as shown.

STEP 5. Push cable and parts into the Main Body until it stops

STEP 6. Crimp it with the crimp tools as shown.

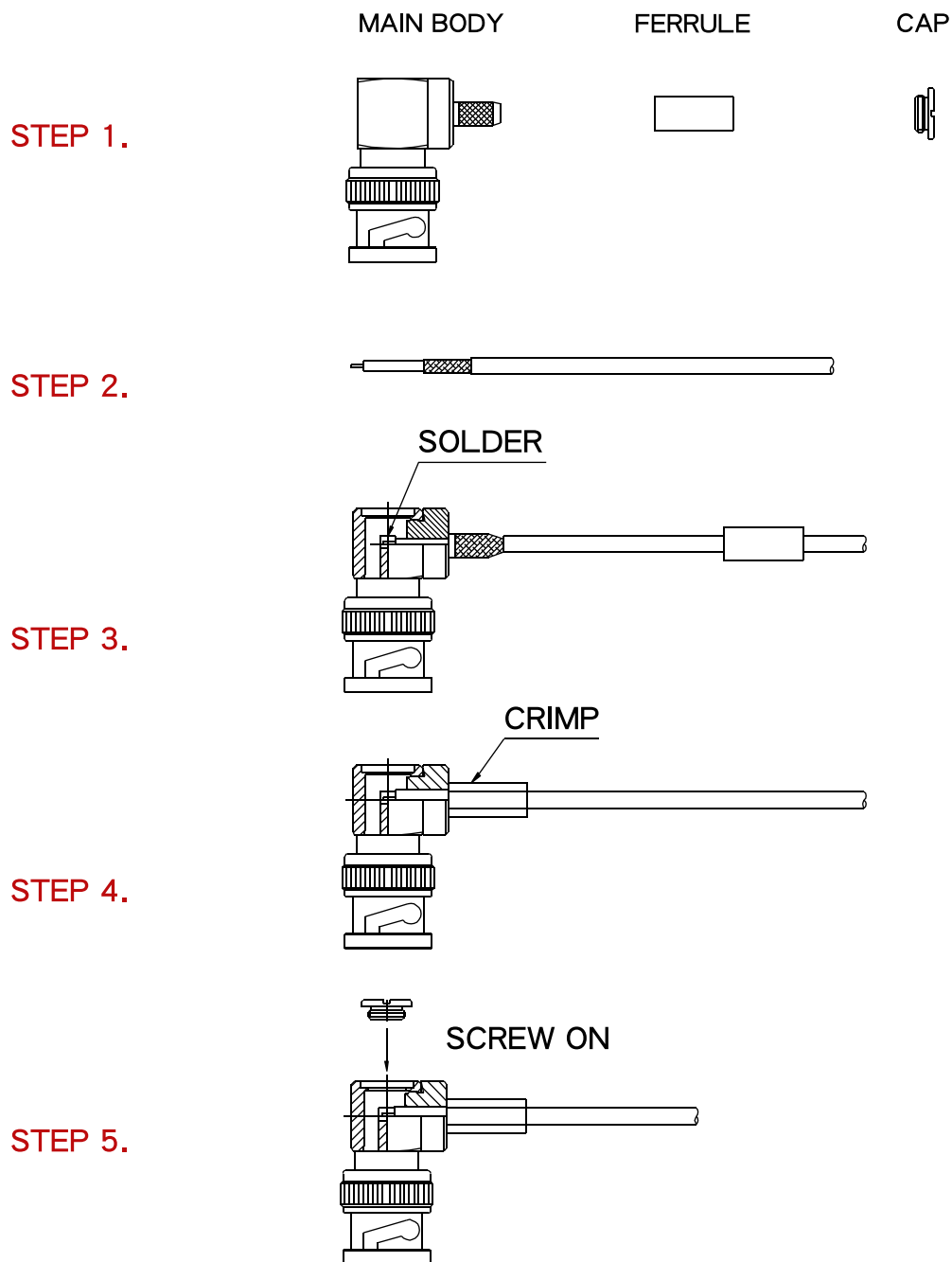

STEP 1. All parts of the connector are shown.

STEP 2. Strip the cable inner conductor, braid, and jacket as per "RECOMMENDED CABLE STRIPPING DIM' S" in catalog

STEP 3. Insert the MAIN BODY and FERRULE into the "RECOMMENDED CABLE STRIPPING DIM' S" and solder it as shown

STEP 4. Crimp it with the crimp tools as shown

STEP 5. Use the CAP to screw on the MAIN BODY gently

Cable Assembly Instruction F

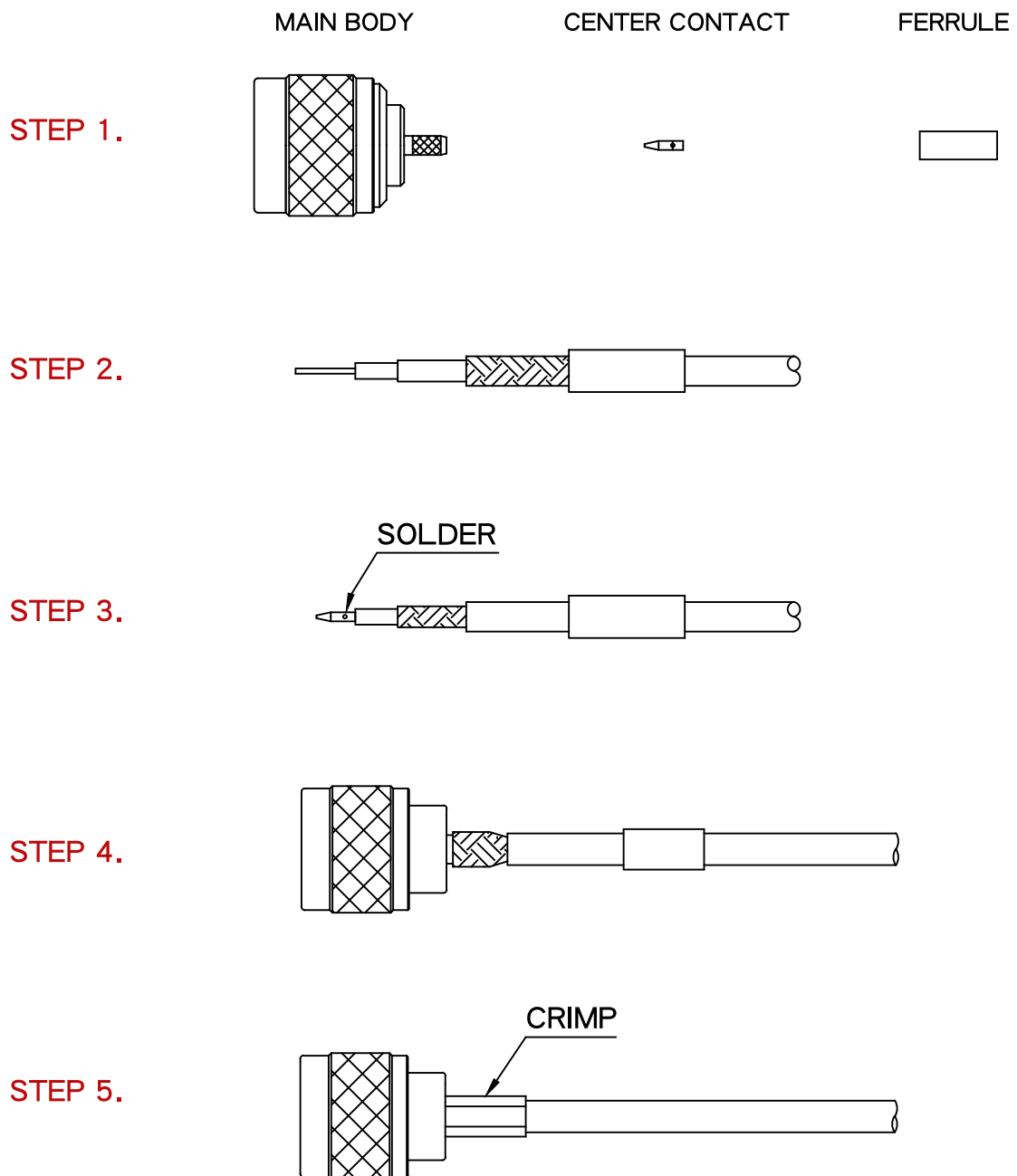

STEP 1. All parts of the connector are shown. A crimp tool is necessary to complete the termination

STEP 2. Strip the cable inner conductor, dielectric, braid, and jacket as per "RECOMMENDED CABLE STRIPPING DIM' S in catalog

STEP 3. Insert inner conductor into the CENTER CONTACT and crimp it with the crimp tool as shown. Then slide the FERRULE onto cable

STEP 4. Insert the MAIN BODY into braid and dielectric

STEP 5. Slide the FERRULE over braid and crimp it with the crimp tool as shown

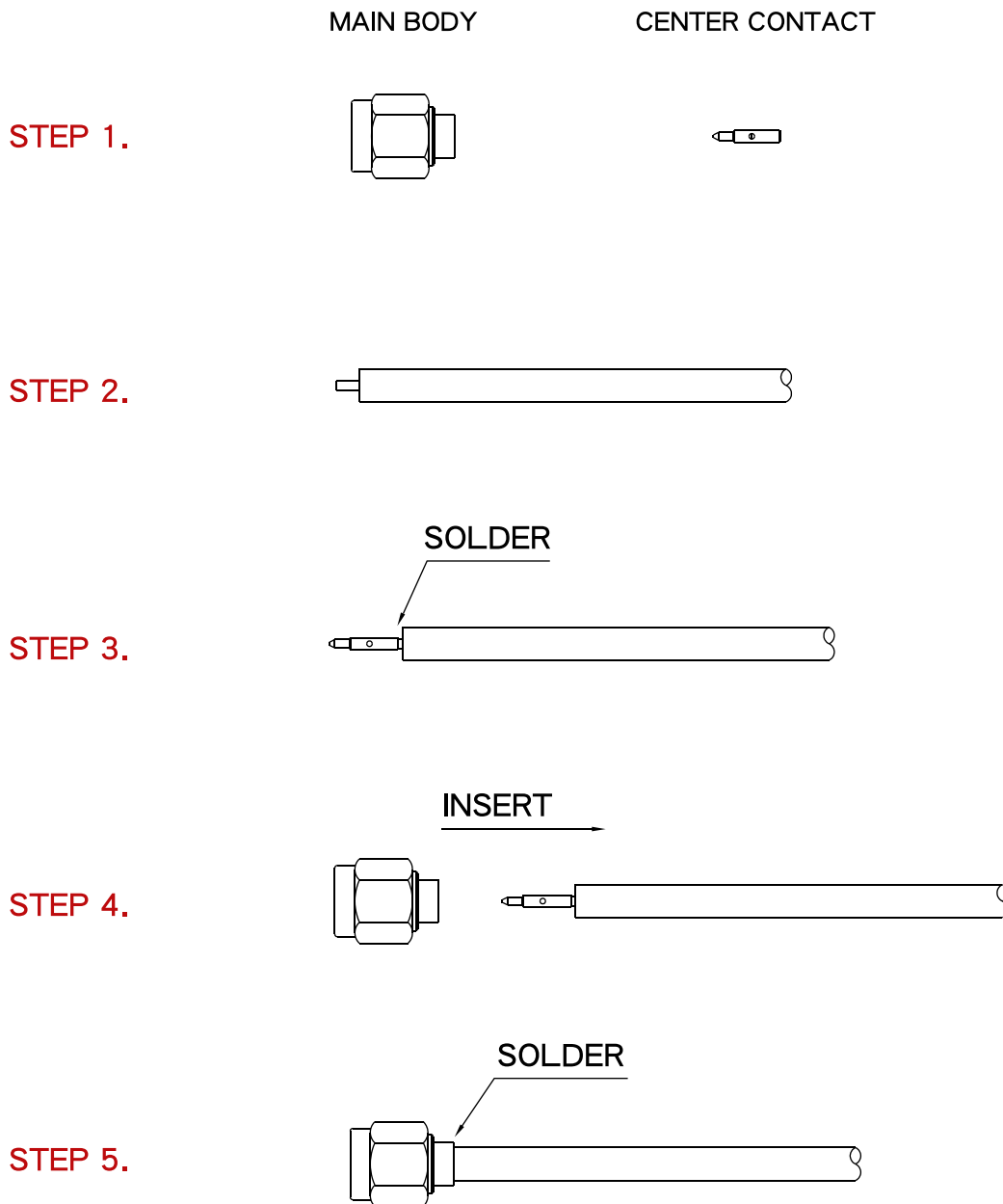

STEP 1. All parts of the connector are shown

STEP 2. Strip the inner conductor, dielectric, and jacket as per
"RECOMMENDED CABLE STRIPPING DIM' S" in catalog

STEP 3. Insert inner conductor into the CENTER CONTACT and solder it as shown

STEP 4. Push cable and parts into the Main Body until it stop

STEP 5. Solder the MAIN BODY to cable as shown.

Cable Assembly Instruction M

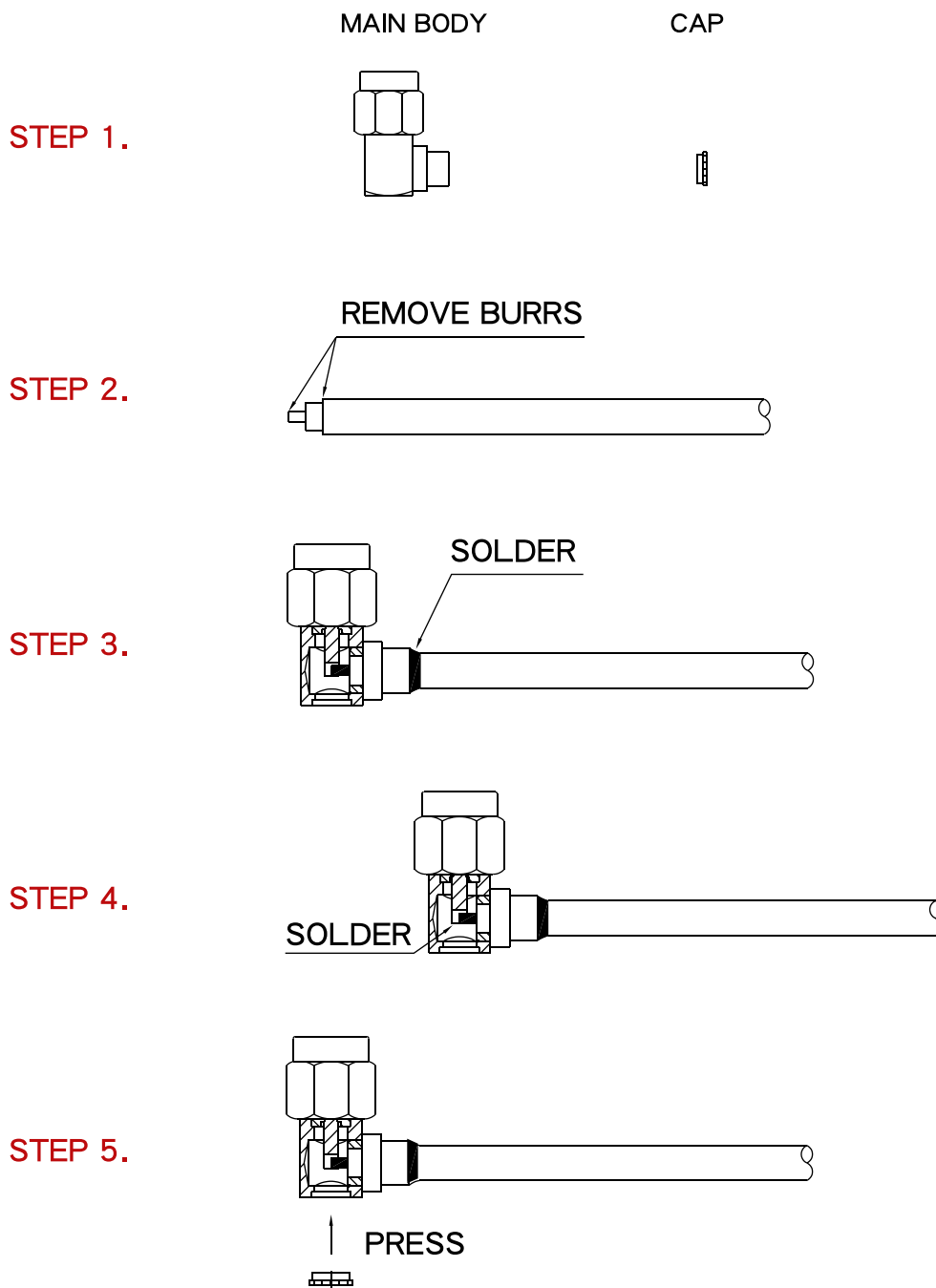

STEP 1. All parts of the connector as shown

STEP 2. Strip the inner conductor, dielectric, and jacket as per
"RECOMMENDED CABLE STRIPPING DIM' S" in catalog

STEP 3. Insert the MAIN BODY into the cable and solder it as shown

STEP 4. Solder the pin of the connector as shown

STEP 5. Press the CAP in to the MAIN BODY until it is flat with the MAIN BODY.

www.socaa.com.tw

ADD / No.50,Lane 486, Jhong Jheng 3RD Street, Yong Kang Dis. 710, Tainan, Taiwan

TEL / 886-6-242-7963

FAX / 886-6-243-4019

MAIL /sales@socaa.com.tw

